Gene Pulser Xcell Electroporation System

Instruction Manual

Catalog numbers

1652660
1652661
1652662
1652666
1652667
1652668
1652669

For technical service call your local Bio-Rad office or in the U.S.
call 1-800-4BIORAD (1-800-424-6723). On the Web at bio-rad.com.



BIO-RAD

Warranty

The Gene Pulser Xcell Electroporation System is warranted against defects in materials and workmanship for 1 year. If any defects occur in the instruments or accessories during this warranty period, Bio-Rad Laboratories will repair or replace the defective parts at its discretion without charge. The following defects, however, are specifically excluded:

1. Defects caused by improper operation.
2. Repair or modification done by anyone other than Bio-Rad Laboratories or an authorized agent.
3. Damage caused by substituting alternative parts.
4. Use of fittings or spare parts supplied by anyone other than Bio-Rad Laboratories.
5. Damage caused by accident or misuse.
6. Damage caused by disaster.
7. Corrosion caused by improper solvent or sample.

This warranty does not apply to the following parts: **Fuses**.

For any inquiry or request for repair service, contact Bio-Rad Laboratories. Inform Bio-Rad of the model and serial number of your instrument.

IMPORTANT: This Bio-Rad instrument is designed and certified to meet EN 61010-1* and the electromagnetic compatibility (EMC) requirements of EN 61326 (for Class A) safety standards. Certified products are safe to use when operated in accordance with the instruction manual. This instrument should not be modified or altered in any way. Alteration of this instrument will:

- Void the manufacturer's warranty
- Void the EN 61010-1 safety certification
- Create a potential safety hazard

Bio-Rad Laboratories is not responsible for any injury or damage caused by the use of this instrument for purposes other than those for which it is intended, or by modifications of the instrument not performed by Bio-Rad Laboratories or an authorized agent.

*EN 61010-1 is an internationally accepted electrical safety standard for laboratory instruments.

Model: Gene Pulser Xcell System _____

Catalog No.: 165xxxx _____

Date of Delivery: _____

Serial No.: _____

Invoice No.: _____

Purchase Order No.: _____

Table of Contents

Section 1	The Gene Pulser Xcell Electroporation System	1
1.1	General Safety Information	1
1.2	Electrical Hazards	2
1.3	Mechanical Hazards	2
1.4	Other Safety Precautions	3
Section 2	Unpacking and System Installation	3
2.1	Unpacking the System Components	4
2.2	Setting up the System	4
2.2.1	Setting up the Gene Pulser Xcell Main Unit and Connecting the ShockPod (Catalog # 1652660, 1652661, 1652662, and 1652666)	4
2.2.2	Connecting the PC Module to the Gene Pulser Xcell Main Unit (Catalog #1652660, 1652662, 165666, and 1652668)	5
2.2.3	Connecting the CE Module to the Gene Pulser Xcell Main Unit (Catalog #1652660, 1652661, 165666, and 1652667)	6
2.2.4	ShockPod (Catalog #1652660, 1652661, 1652662, and 1652669)	6
Section 3	Gene Pulser Xcell System Operating Instructions	8
3.1	Front Panel and Home Screen	8
3.1.1	Front Panel Keypad	8
3.1.2	Home Screen	9
3.1.3	Help Screens	10
3.2	Manual Operation	10
3.2.1	Manual Operation (Quick Guide)	10
3.2.2	Electroporation Using Exponential Decay Pulses	11
3.2.3	Electroporation Specifying Time Constant	12
3.2.4	Electroporation Using Square-Wave Pulses	13
3.2.5	Results Screens	15

3.2.6	Saving a Program from Manual Operation	16
3.2.6A	Saving a Protocol in a Location without a Named User Protocol Entry	16
3.2.6B	Saving a Protocol in a Location with a Named User Protocol Entry	17
3.3	Preset Protocols	17
3.3.1	Using a Preset Protocol (Quick Guide)	18
3.3.2	Electroporation using a Preset Protocol	18
3.3.3	Modifying Preset Protocol Parameters	20
3.3.4	Saving Changes to Preset Protocols	21
3.4	User Protocols	21
3.4.1	Using a User Protocol (Quick Guide)	21
3.4.2	Creating a New User Name	22
3.4.3	Creating a New User Protocol	22
3.4.4	Modifying a User Protocol	25
3.4.5	Deleting a User Name and a User Protocol	26
3.4.6	Changing a User Name or a User Protocol Name	27
3.5	Last Pulse	28
3.6	Optimize Operation	28
3.7	Data Management	30
3.8	Measurements	33
3.8.1	Sample Resistance Measurements	33
3.8.2	Calibration and Measurement of Capacitors in the CE Module	33
3.9	User Preferences	34
3.9.1	Setting the Clock	35
3.9.2	Adjusting the Screen Intensity	35
3.9.3	Sleep Function Setting	36
3.10	The Pulse Trac System	36
3.10.1	Pulse Trac System Description	36
3.10.2	Pulse Trac Diagnostic Algorithm	37

Section 4	Overview of Electroporation Theory	37
4.1	Exponential Decay Pulses	38
4.2	Square-Wave Pulses	38
Section 5	Factors Affecting Electroporation: Optimizing Electroporation	39
5.1	Cell Growth	40
5.2	DNA	40
5.3	Electroporation Media	41
5.4	Temperature	41
Section 6	Electroporation of Bacterial Cells	43
6.1	<i>Escherichia coli</i>	43
6.1.1	Preparation of Electrocompetent Cells.	43
6.1.2	Electroporation	44
6.1.3	Solutions and Reagents	44
6.2	<i>Staphylococcus aureus</i>	45
6.2.1	Preparation of Electrocompetent Cells.	45
6.2.2	Electroporation	45
6.2.3	Solutions and Reagents	46
6.3	<i>Agrobacterium tumefaciens</i>	46
6.3.1	Preparation of Electrocompetent Cells.	46
6.3.2	Electroporation	47
6.3.3	Solutions and Reagents	48
6.4	<i>Bacillus cereus</i>	48
6.4.1	Preparation of Electrocompetent Cells.	48
6.4.2	Electroporation	48
6.4.3	Solutions and Reagents	49
6.5	<i>Pseudomonas aeruginosa</i>	49
6.5.1	Preparation of Electrocompetent Cells.	49
6.5.2	Electroporation	50
6.5.3	Solutions and Reagents	50

6.6	<i>Streptococcus pyogenes</i>	51
6.6.1	Preparation of Electrocompetent Cells.	51
6.6.2	Electroporation	51
6.6.3	Solutions and Reagents	52
6.7	<i>Lactobacillus plantarum</i>	52
6.7.1	Preparation of Electrocompetent Cells.	52
6.7.2	Electroporation	53
6.7.3	Solutions and Reagents	53

Section 7 Electroporation of Fungal Cells 54

7.1	<i>Saccharomyces cerevisiae</i>	54
7.1.1	Preparation of Electrocompetent Cells.	54
7.1.2	Electroporation	55
7.1.3	Solutions and Reagents	55
7.2	<i>Schizosaccharomyces pombe</i>	55
7.2.1	Preparation of Electrocompetent Cells.	55
7.2.2	Electroporation	56
7.2.3	Solutions and Reagents	56
7.3	<i>Pichia pastoris</i>	57
7.3.1	Preparation of Electrocompetent Cells.	57
7.3.2	Electroporation	57
7.3.3	Solutions and Reagents	58
7.4	<i>Candida albicans</i>	58
7.4.1	Preparation of Electrocompetent Cells.	58
7.4.2	Electroporation	59
7.4.3	Solutions and Reagents	60
7.5	<i>Dictyostelium discoideum</i>	60
7.5.1	Preparation of Electrocompetent Cells.	60
7.5.2	Electroporation	60
7.5.3	Solutions and Reagents	61

Section 8	Electroporation of Mammalian Cells	61
8.1	Preparation of Electrocompetent Cells	61
8.1.1	Attached Cells	61
8.1.2	Suspension Cells	62
8.2	Electroporation	62
8.3	Solutions and Reagents	63
Section 9	References	63
Section 10	Specifications and Product Information	65
10.1	System Specifications	65
10.2	Ordering Information	67

Section 1

The Gene Pulser Xcell Electroporation System

The Gene Pulser Xcell Electroporation System is a pulse generator that uses capacitors to produce controlled exponential or square-wave electrical pulses for cell electroporation. The unit is capable of producing pulses of up to 3,000 V on a high-voltage circuit and up to 500 V on a low-voltage circuit. For generating pulses on the high-voltage circuit, capacitors of 10, 15, and 25 μF present in the Gene Pulser Xcell main unit are used, and generating pulses on the low-voltage circuit requires use of capacitors in the CE module. Exponential decay (or capacitance discharge) and square-wave pulses are the most commonly used types of electrical pulse. An in-depth discussion of these two waveforms can be found in Section 4.

The Gene Pulser Xcell System is a modular system, comprising a main unit and two accessory modules, the CE module and the PC module, in addition to the shocking chamber and a cuvette with incorporated electrodes.

The CE module is recommended for use with the Gene Pulser Xcell main unit for electroporation of most eukaryotic cells, including mammalian cells and plant protoplasts. The CE module should only be used with low-resistance media ($<1,000 \Omega$). For exponential decay pulses, the CE module provides a means of controlling the capacitance of the circuit by increasing the time constant of the pulse. For square-wave pulses, the CE module provides the large capacitor necessary for delivering a square-wave pulse into low-resistance media. This module contains a set of capacitors with a functional range between 50 and 3,275 μF and selectable in 25- μF increments. For square-wave pulses, the CE module provides the large capacitance, 3,275 μF , necessary for delivering a square-wave pulse into low-resistance media.

The PC module is recommended for the electroporation of bacteria and fungi using exponential decay, as well as in other applications where high-voltage pulses are applied to samples of small volume and high resistance. The PC module selects resistance of 50–1,000 Ω in 50- Ω increments. The unit is used to control the resistance of the circuit by placing resistors in parallel with the sample, thereby providing a means of reducing the time constant of an exponential decay pulse. This provides an effective means of controlling the time constant when using high-resistance media but has little effect on the time constant when using low-resistance media. The PC module greatly reduces the likelihood of an arc occurring at high voltage. It is not recommended that the PC module be used for square-wave pulses due to the increase in droop of the pulse that can occur (see Section 4).

Both the PC module and CE module have integral leads that connect to the main unit (see Section 2 for installation), and both units are controlled directly from the user interface on the front panel of the main unit.

1.1 General Safety Information

This Bio-Rad instrument is designed and certified to meet the safety requirements of EN 61010-1 and the electromagnetic compatibility (EMC) requirements of EN 61326 (for Class A) and conforms to the “Class A” standards for electromagnetic emissions intended for laboratory equipment applications. This instrument is intended for laboratory application only. It is possible that emissions from this product may interfere with some sensitive appliances when placed nearby or in the same circuit as those appliances. The user should be aware of this potential and take appropriate measures to avoid interference.

No part of the Gene Pulser Xcell System should be used if obvious external case damage has occurred or the electronic displays are not functioning as described in the manual. This instrument is only to be used with the components provided (or their authorized additions or replacements), including but not limited to supplied cables and Gene Pulser Xcell ShockPod Cuvette Chamber.

Environmental operating conditions:

- Operating temperature: 0–35°C, indoor use
- Humidity: 0–95%, in the absence of condensation
- Altitude: Up to 2,000 m
- Pollution degree: 2

Input power information:

- Supply voltage fluctuations: +/-10% (unless otherwise specified), maximum current 2 A, maximum power 240 W
- Overvoltage category: II

There are no user-serviceable parts within the unit. The operator should make no attempt to open any case cover or defeat any safety interlock. This instrument must not be altered or modified in any way. Alteration of this instrument will

- Void the manufacturer's warranty
- Void the IEC 1010 safety certification
- Create a potential safety hazard

Bio-Rad is not responsible for any injury or damage caused by the use of this instrument for purposes other than those for which it is intended or by modification of the instrument not performed by Bio-Rad or an authorized agent.

1.2 Electrical Hazards

The Gene Pulser Xcell System produces voltages up to 3,000 V and is capable of passing very high currents. When charged to maximum voltage, the instrument stores about 400 J. A certain degree of respect is required for energy levels of this order. System safety features prevent operator access to the recessed input jacks and to the recessed electrode contacts inside the sample chamber. These mechanical interlocks should never be circumvented.

The pulse button is active whenever the character space in the lower right corner is flashing. There is high voltage present whenever the pulse button is depressed and “Pulsing” is shown on the LCD display on the front of the instrument. Because of the built-in safety interlock in the ShockPod, no pulse is delivered to the cuvette when the ShockPod lid is opened. If the capacitor has been partially charged but not fired (for example, when the charging cycle has been interrupted before the pulse is delivered), some charge may remain on the internal capacitor. This charge will dissipate over 1–2 minutes. However, the user cannot make contact with any charged electrical components due to the system safety features.

1.3 Mechanical Hazards

The Gene Pulser Xcell System contains an arc-protection circuit that dramatically reduces the incidence of arcing in the cuvette when high voltage is delivered into the sample. The unit incorporates a circuit that senses the beginning of an arc and diverts current from the sample within <math><10\ \mu\text{s}</math>, preventing or greatly reducing mechanical, visual, and auditory phenomena at the ShockPod. Should an arc occur, the sample chamber is effective in containing these small discharges; nonetheless, we strongly recommend wearing safety glasses when using the instrument.

1.4 Other Safety Precautions

Avoid spilling any liquids onto the apparatus. Use only a paper towel or a cloth wet with either water or alcohol to clean the outside surfaces of the Gene Pulser Xcell System.

Use only the Bio-Rad cables supplied with the Gene Pulser Xcell System.

Use the ShockPod only in the assembled condition. Do not attempt to circumvent the protection of the ShockPod or use it while disassembled. Verify the display segments periodically.

Read the instruction manual before using the Gene Pulser Xcell System. For technical assistance contact your local Bio-Rad office or, in the US, call technical services at **1-800-4BIORAD (1-800-424-6723)**.

Warning: The Gene Pulser Xcell System generates, uses, and radiates radio frequency energy. If it is not used in accordance with the instructions given in this manual, it may cause interference with radio communications. The Gene Pulser Xcell System has been tested and found to comply with the limits for Class A computing devices (pursuant to Subpart J of Part 15 of FCC Rules), which provide reasonable protection against such interference when operated in a commercial environment. Operation of this equipment in a residential area is likely to cause interference. In this case the user will be required, at their expense, to take whatever measure may be required to correct the interference.

Section 2 Unpacking and System Installation

The Gene Pulser Xcell System can be purchased as three systems as well as component parts:

- 1652660 Gene Pulser Xcell Total System for eukaryotic and prokaryotic cells, 100/240 V, 50/60 Hz, exponential-decay and square-wave delivery, includes main unit, CE module, PC module, ShockPod, 15 sterile cuvettes (5 each of 0.1, 0.2, and 0.4 cm gap), instruction manual
- 1652661 Gene Pulser Xcell Eukaryotic System, 100/240 V, 50/60 Hz, includes main unit, CE module for exponential-decay or square-wave pulses, shocking chamber, 5 x 0.4 cm gap sterile electroporation cuvettes, cuvette rack
- 1652662 Gene Pulser Xcell Microbial System, 100/240 V, 50/60 Hz, includes main unit, PC module for exponential-decay pulse delivery, shocking chamber, 5 each of 0.1 and 0.2 cm sterile electroporation cuvettes, cuvette rack
- 1652666 Gene Pulser Xcell Main Unit, 100/240 V, 50/60 Hz
- 1652667 Gene Pulser Xcell CE module, capacitance extender for use with the Gene Pulser Xcell electroporation system, functional range of 25–3,275 μF , includes integral leads
- 1652668 Gene Pulser Xcell PC module, pulse controller module for use with the Gene Pulser Xcell electroporation system, range of 50–1,000 Ω , includes integral leads
- 1652669 Gene Pulser Xcell ShockPod Cuvette Chamber, electroporation chamber of the Gene Pulser Xcell and Gene Pulser II electroporation systems, includes integral leads

2.1 Unpacking the System Components

Remove all packing material and connect components on a flat, dry surface near an appropriate electrical outlet.

Upon receiving your instrument, please check that all items listed were shipped. If any items are missing or damaged, contact your local Bio-Rad office.

2.2 Setting Up the System

2.2.1 Setting Up the Gene Pulser Xcell Main Unit and Connecting the ShockPod (Catalog #1652660, 1652661, 1652662, and 1652666)

Follow this procedure for setting up the Gene Pulser Xcell System and connecting the ShockPod. Be sure to turn off the Gene Pulser Xcell main unit before connecting or disconnecting the power cord or any cables.

1. Attach the power cord to the three-pronged receptacle on the back of the Gene Pulser Xcell unit (Figure 2.1A). Plug the unit into an appropriate electrical outlet or power strip. There is a foot on the bottom of the Gene Pulser Xcell System which may be pulled down to change the viewing angle of the LCD display (Figure 2.1B).
2. Insert the black connector of the ShockPod into the left and center output jacks on the front panel of the Gene Pulser Xcell System (Figure 2.2); polarity is not important to the electroporation process. The right output jack is not used with the ShockPod.
3. To turn on the Gene Pulser Xcell System, press the power switch on the right rear of the instrument (Figure 2.2).

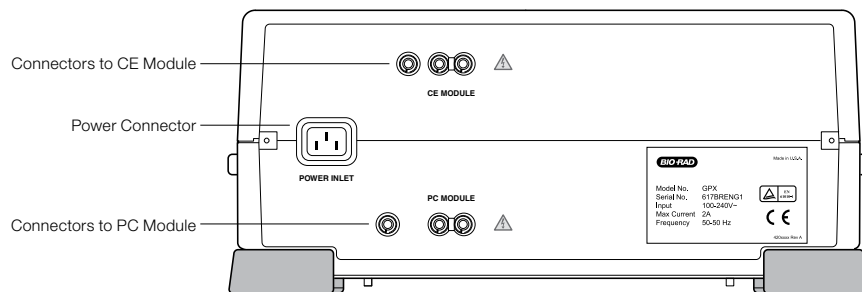

Fig. 2.1A. Rear panel of the Gene Pulser Xcell main unit showing receptacles for the power cord, CE module, and PC module.

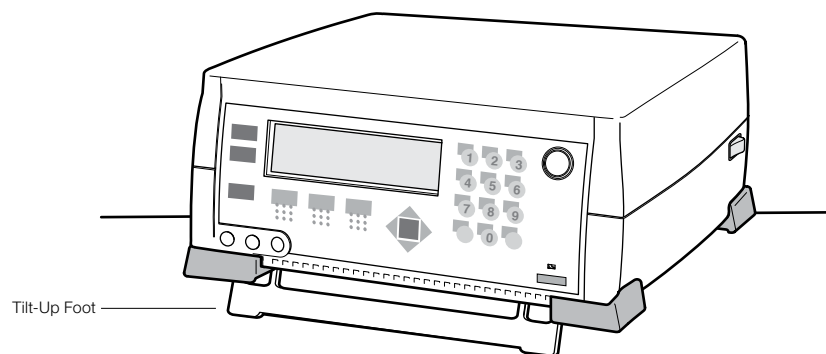

Fig. 2.1B. Bottom panel of the Gene Pulser Xcell main unit. The foot may be pulled down to raise the front of the unit.

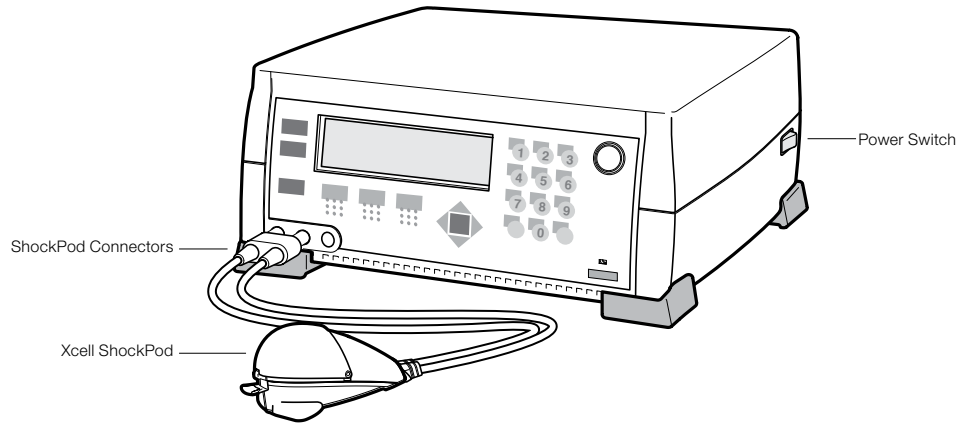

Fig. 2.2. Connecting the ShockPod to the Gene Pulser Xcell main unit.

2.2.2 Connecting the PC Module to the Gene Pulser Xcell Main Unit (Catalog #1652660, 1652662, 1652666, and 1652668)

The PC module and CE module may be connected to the Gene Pulser Xcell main unit in any order and both may be connected at the same time. Before connecting the PC module to the Gene Pulser Xcell System, be sure that the Gene Pulser Xcell System is turned off. There is no power switch on the PC module; it is controlled entirely by the Gene Pulser Xcell main unit.

1. Place the PC module near the Gene Pulser Xcell main unit. The units, along with the CE module, are stackable; either the PC module or the Gene Pulser Xcell main unit can be placed on the bottom. Place the feet of the top unit at the corners of the bottom unit to interlock the two.
2. Insert the red/black connector that is permanently attached to the cable on the back of the PC module into the appropriately labeled receptacle on the back of the Gene Pulser Xcell main unit (see Figure 2.3). The connector is keyed so that it will insert only into the proper receptacle and in the correct red/black orientation.

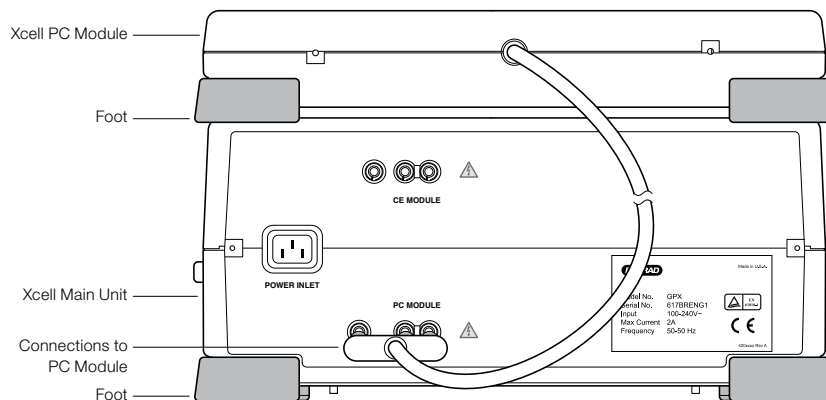

Fig. 2.3. Rear view (back panel) of the PC module showing the connection to the Gene Pulser Xcell main unit.

2.2.3 Connecting the CE Module to the Gene Pulser Xcell Main Unit (Catalog #1652660, 1652661, 1652666, and 1652667)

The PC module and CE module may be connected to the Gene Pulser Xcell main unit in any order and both may be connected at the same time. Before connecting the CE module to the Gene Pulser Xcell System, be sure that the Gene Pulser Xcell System is turned off. There is no power switch on the CE module; it is controlled entirely by the Gene Pulser Xcell System unit.

1. Place the CE module near the Gene Pulser Xcell main unit. These units, along with the PC module are stackable in any order. Place the feet of the top unit at the corners of the bottom unit to interlock the two.
2. Insert the red/black connector that is permanently attached to the cable on the back of the CE module (Figure 2.4) into the appropriately labeled receptacle on the back of the Gene Pulser Xcell main unit (see Figure 2.1). The connector is keyed so that it will insert only into the proper receptacle in the correct red/black orientation.

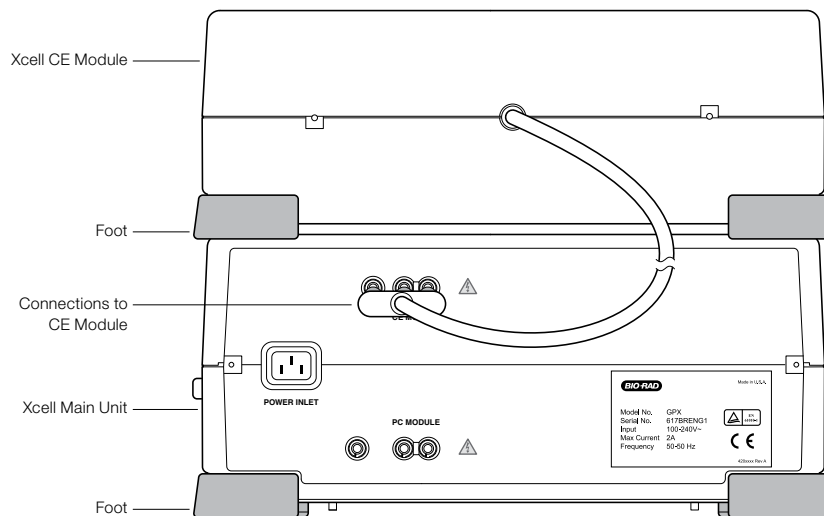

Fig. 2.4. Rear view (back panel) of the CE module showing the connection to the Gene Pulser Xcell main unit.

2.2.4 ShockPod (Catalog #1652660, 1652661, 1652662, and 1652669)

The ShockPod is designed for one-hand operation (Figure 2.5). Press the tab on the front of the chamber to release the latch and to open the top. Push the top down gently to close the chamber. The safety design of the system requires that the top be closed before pulsing can occur. Additionally, the top must be closed to use the ShockPod to measure resistance of electroporation medium (see Section 3.9.1). Because of the built-in safety interlock in the ShockPod, no pulse is delivered to the cuvette when the ShockPod lid is opened.

The cuvette slot will accept any commercially available cuvette. Bio-Rad cuvettes are designed with a notch on one of the nonelectrode sides so they may be inserted into the cuvette slot only in the proper orientation.

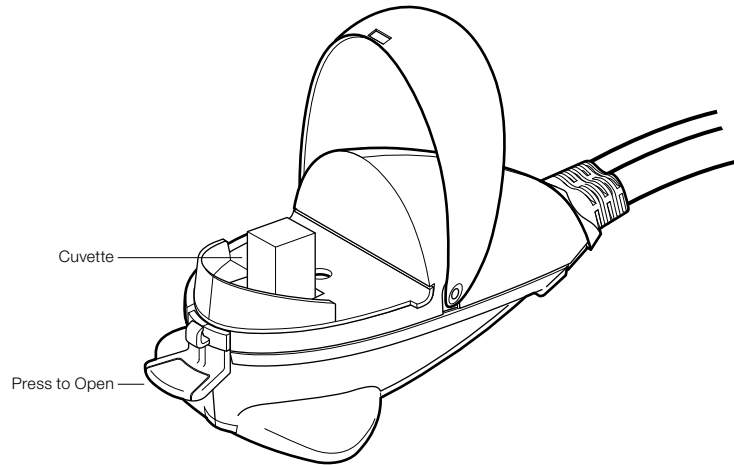

Fig. 2.5. ShockPod with cuvette.

The plastic panel covering the electrode may be removed for cleaning should the electrode become dirty. To clean the unit:

1. Disconnect the ShockPod from the Gene Pulser Xcell main unit.
2. Press the tab to open the chamber.
3. Using a Phillips screwdriver, loosen the screw holding the safety panel (Figure 2.6). Lift the screw and the safety panel out of the ShockPod by the lip on the front of the panel.
4. The area around the electrodes may be cleaned with a cotton swab and warm, soapy water. Dry the electrodes using a dry cotton swab or Kimwipe.
5. Reassemble the unit by centering the safety panel on the base of the ShockPod and tightening the screw.

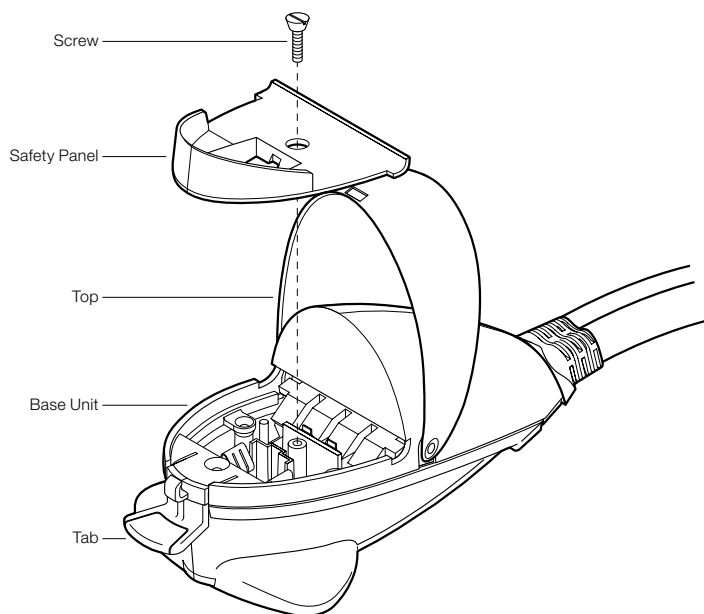

Fig. 2.6. Exploded view of the Gene Pulser Xcell System ShockPod.

Section 3

Gene Pulser Xcell System Operating Instructions

3.1 Front Panel and Home Screen

3.1.1 Front Panel Keypad

The keys on the front panel of the main unit control the Gene Pulser Xcell System (Figure 3.1).

Alpha-Numeric keys	This array of keys permits entering numbers and letters into the Gene Pulser Xcell System. Pressing the Shift key toggles between alphabetic and numeric input. To type an alphabetic character, press the Shift key to enter alpha mode, then press the key with the appropriate letter. To type an a , press the 2 key once; to type a b , press the 2 key twice; to type a c , press the 2 key three times. To use the same key twice, for example, to type a then b, advance the cursor using the Right Arrow key. The firmware on the Gene Pulser Xcell System will automatically change between alpha and numeric input depending on the parameter being entered. In Protocol screens and Directory screens where a two-digit entry must be made, the second digit must be entered within 2 seconds of the first entry, otherwise the screen will default to the single-digit entry.
Home key	Returns the user to the Home screen from anywhere in the program.
Back key	Returns the user one level back in hierarchy toward the Home screen.
Help key	Displays on-screen help text.
Save key	Saves User Names and User Protocols.
Delete key	Removes only the last entry in the field; also used to remove User Name and User Protocol files.
Clear key	Removes the entire line of the field.
Enter key	Indicates that a choice has been made and moves the cursor to the next location.
Arrow keys	The Up and Down Arrow keys move the cursor up or down one row at a time. Depending on the screen and location of the cursor, the Right and Left Arrows may (1) move the cursor right or left one space at a time, (2) toggle forward and backward one screen when there are multiple screens for the same menu, or (3) increase or decrease numerical input values.
Pulse button	Results in discharging a pulse. During this time “Pulsing” is shown on the LCD display. A tone sounds to indicate that the pulse has been delivered. When multiple pulses are delivered, a tone sounds after the last pulse has been delivered. The Pulse is discharged to the electrodes if the ShockPod is connected and the lid is closed. Otherwise, it is discharged safely within the instrument.

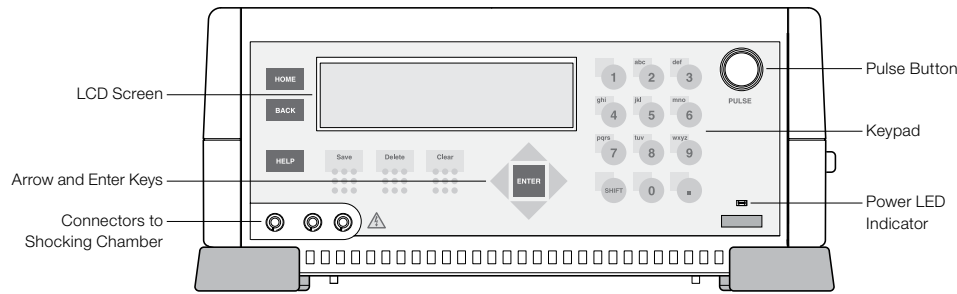

Fig. 3.1. Gene Pulser Xcell System front panel. See Section 3.1.1 for an explanation of the key functions.

3.1.2 Home Screen

The Home screen provides easy access to programs built into the Gene Pulser Xcell System as well as a direct method of manually entering pulse parameters to electroporate a sample.

Upon turning on the power to the Gene Pulser Xcell System, the unit will run a series of test algorithms, including a check of the Pulse Trac system (see Section 3.10) and the firmware. During this time the LCD will display the Bio-Rad logo, the product name, and the version of firmware. After this instrument initialization, the Home Screen is displayed (Figure 3.2). From this screen it is easy to access the programs described below. You may return to this screen from anywhere in the program by pressing the Home key on the keypad.

Home consists of two screens. The first contains the most commonly used programs. The second contains advanced functions. The Left and Right Arrow keys can be used to toggle between them.

To select a program, when the Home screen is displayed, press numbers 1–10 on the alpha-numeric keypad followed by the Enter key. Alternatively, use the Up and Down Arrow keys to scroll to the desired selection; press Enter to select the program.

1. Exponential protocol: for delivery of an exponential decay pulse: enables the user to program a set of conditions and to deliver the pulse.
2. Time constant protocol: for delivery of an exponential decay pulse by specifying a time constant: enables the user to program a set of conditions and to deliver the pulse.
3. Square wave protocol: for delivery of a square-wave pulse: enables the user to program a set of conditions and to deliver the pulse.
4. Preset protocols: preprogrammed optimized settings for electrotransformation of commonly used bacterial, fungal, and mammalian cells.
5. User protocols: a program which allows the user to store up to 144 protocols, including all instrument settings, and to recall these protocols to deliver a pulse.
6. Last pulse: allows the user to recall the electroporation parameters for the last pulse and to deliver a pulse using the same conditions.
7. Optimize: allows the user to program electroporation parameters and an increment for voltage that may be changed after each pulse in order to optimize electroporation conditions.
8. Data management: allows the user to access pulse parameters and results for the last 100 pulses logged by date and time.

9. Measurements: allows the user to measure capacitor values in the Gene Pulser Xcell System or CE module and to measure sample resistance.
10. User preferences: allows the user to adjust the clock, the screen light intensity, and the LCD sleep function.

Right and left arrows (> and <) appear at the bottom of the first screen and at the top of the second screen, respectively. These arrows indicate that the Right and Left Arrow keys may be used to toggle between these related screens.

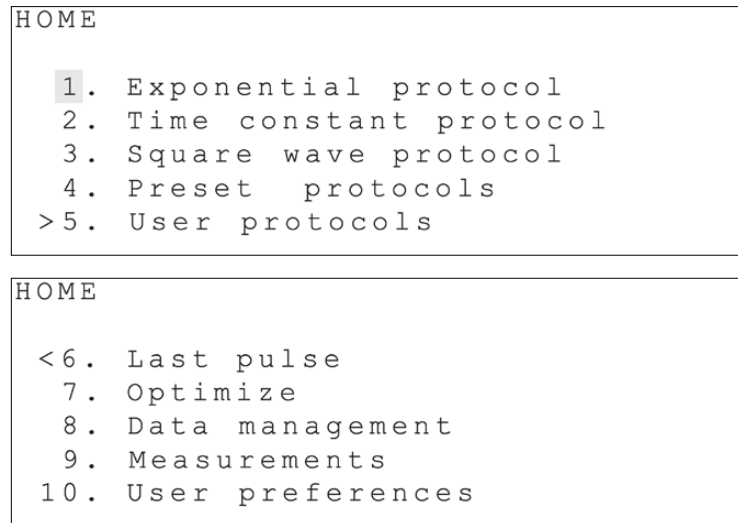

Fig. 3.2. Gene Pulser Xcell System Home screens. All menu functions may be readily accessed from these screens. Return to the Home screen from anywhere in the program by pressing the Home key. Press the Left and Right Arrow keys to toggle between the two screens.

3.1.3 Help Screens

On-screen help is built into the software of the Gene Pulser Xcell System. This may be accessed from any screen.

Help screens are accessible from all screens by pressing the Help key. Each help menu describes the keystrokes that may be entered to choose the next function or to continue the current operation. Where there is more than one help screen, use the Right and Left Arrow keys to scroll between them. To return to the program screen, press the Back key.

3.2 Manual Operation

Manual mode allows for rapid parameter programming necessary to deliver either an exponential decay or a square-wave pulse.

3.2.1 Manual Operation (Quick Guide)

- From the Home screen:
 - Press Enter to select exponential decay
 - Press 2, then Enter to select exponential decay but specifying a time constant
 - Press 3, then Enter to select square-wave

- Use the Up and Down Arrow keys to scroll through the parameter value spaces on the screen
- When a parameter value is highlighted, use the keypad to enter a value, then press Enter to accept that value
- When the necessary parameter values have been entered, the Pulse button on the Gene Pulser Xcell System is active
- Press the Pulse button to electroporate the sample
- Press the Back key to return to the Protocol Detail screen and to deliver another pulse

3.2.2 Electroporation Using Exponential Decay Pulses

See Section 4.1 for a discussion of electroporation using exponential decay pulses.

- When the Home screen (Figure 3.2) is selected, the number 1 corresponding to “Exponential protocol” is highlighted as the default choice. Press Enter to view the Protocol Detail Screen. If the number 1 on the Home screen is not highlighted, press 1 or use the Up or Down Arrow keys to highlight “Exponential protocol,” then press Enter to select. The Protocol Detail screen appears (Figure 3.3)
- The following combination of parameters may be entered:

Capacitance + Voltage
 Capacitance + Voltage + Resistance

The three variables may be selected in any order; however, the set voltage will determine whether the high-voltage or the low-voltage circuit is to be used and will limit the range of the capacitance as indicated in Table 3.1. If a value for the capacitance is chosen that is outside the range of the system, this value will default to the closest allowable value.

Specifying a resistance value requires that the PC module be attached. This is always recommended with high-resistance media (i.e., $>600 \Omega$), such as water, sucrose, glycerol, sorbitol, or polyethylene glycol. The PC module places a resistor in parallel with the sample to reduce the resistance of the circuit. In this way, the time constant of a high-resistance sample may be reduced and controlled.

When the Resistance value indicates infinity, no resistors from the PC module are used. The Measurements function of the Gene Pulser Xcell System may be used to determine sample resistance (see Section 3.8).

```

PROTOCOL DETAIL:  EXPONENTIAL

Voltage (V)           XXXX
Capacitance (µF)     XXXX
Resistance (ohm)      XXXX
Cuvette (mm)         X
  
```

Fig. 3.3. Exponential Decay Protocol Detail Screen. This screen shows the parameters that may be specified for exponential-decay electroporation. Entering the cuvette size is optional and is for user information only.

Table 3.1. Capacitance and voltage ranges for the high-voltage/low-capacitance circuit and the low-voltage/high-capacitance circuit of the Gene Pulser Xcell System for delivering an exponential decay pulse.

	Capacitance, μF	Voltage, V	
		$R_{\text{sample}} < 600$	$R_{\text{sample}} > 600$
HV Circuit	10–50	200–2,500	200–3,000
LV Circuit*	25–3,275	10–500	10–500

*Use of the low-voltage circuit requires that the CE module be in place.

- Use the Up and Down Arrow keys to scroll through and highlight the parameter value spaces for capacitance, voltage, or resistance. Use the alpha-numeric keypad to input the desired value, or use the Right and Left Arrow keys to increase or decrease the parameter value by the smallest allowable increment. Use the Delete or Clear keys to change the value. When the desired value has been specified, press Enter. If a value outside the limits of the Gene Pulser Xcell System is selected, the value in the field will default to the closest permitted value. Entering a value for cuvette size is optional and is for user information only
- When the necessary parameter values have been specified, a flashing “P” appears in the character space in the lower right corner of the LCD display indicating that the pulse button on the Gene Pulser Xcell System is active and that a pulse may be delivered
- Press the Pulse button to deliver a pulse. When the Pulse button is depressed, the LCD display will blank then show “Pulsing.” Upon completion, a tone will sound and the pulse measurements will be displayed on the Protocol Results screen (see Figure 3.6, Section 3.2.5)
- Use the Left and Right Arrow keys to toggle between the Protocol Results screen and the last Protocol Detail screen
- With the Protocol Detail screen on the LCD display, another pulse can be delivered using the same pulse parameters. To change the pulse conditions, press Enter; the cursor appears in the voltage parameter value. The parameters may be changed as described above. To save the pulse parameters, see Section 3.2.6
- To review previously delivered pulses, see Section 3.7

3.2.3 Electroporation Specifying Time Constant

See Section 4.1 for a discussion of electroporation using exponential decay. Use the Gene Pulser Xcell System to deliver an exponential decay pulse with a specific time constant as follows:

- From the Home screen (Figure 3.2), press 2 or use the Up or Down Arrow keys to highlight “Time constant protocol,” then press Enter. The Time Constant Protocol Detail screen appears (Figure 3.4)
- A sample must be in place to use the Gene Pulser Xcell System in this mode. The following parameters must be entered:

Time constant + Voltage

In time constant mode, the Gene Pulser Xcell System will maximize the parallel resistance (and minimize the capacitance) in order to maximize the energy delivered to the sample. Therefore, the PC module is required to deliver pulses using the high-voltage circuit, while both the CE module and PC module are needed to deliver pulses using the low-voltage circuit. The set voltage will determine whether the high-voltage or the low-voltage circuit is to be used and will limit the range of the capacitance as indicated in Table 3.2. If a voltage is chosen that spans both the low-voltage and high-voltage range, the Gene Pulser Xcell System will preferentially use the low-voltage circuit. As indicated in Table 3.2, the acceptable values for the time constant are a function of the sample resistance and the voltage circuit used.

Immediately before delivering a pulse, the Gene Pulser Xcell System will determine sample resistance to determine whether a pulse can be delivered using the set parameters of voltage and time constant. If the set time constant is outside the range by more than 20%, the Gene Pulser Xcell System will show a message indicating the approximate time constant that can be delivered and ask that you press the pulse button again to deliver the pulse. To estimate sample resistance using the Gene Pulser Xcell System, see Section 3.8.

Table 3.2. Ranges of time constants that may be achieved using the Gene Pulser Xcell System at several sample resistances.

Sample Resistance, Ω	Time Constant Range, ms	
	LV Circuit*	HV Circuit**
20	0.5–65.5	0.2–1.0
200	5.0–655	2.0–10
>1,000	25–3,275	10–50

* LV Circuit range: 10–500 V

** HV Circuit range: 200–3,000 V

```

PROTOCOL DETAIL: TIME CONSTANT

Voltage (V)                XXXX
Time constant (msec)      XXXX.X
Cuvette (mm)              X

```

Fig. 3.4. Time Constant Protocol Detail Screen. This screen shows the parameters that may be specified for exponential decay electroporation when the time constant is designated. Entering the cuvette size is optional and is for user information only.

- Use the Up and Down Arrow keys to highlight the parameter value space for voltage or time constant. Use the alpha-numeric keypad to input the desired value, or use the Right and Left Arrow keys to increase or decrease the parameter value by the smallest allowable increment. Use the Delete or Clear keys to correct entries. When the desired value has been specified, press Enter. If a value outside the limits of the Gene Pulser Xcell System is selected, the value in the field will default to the closest permitted value. Entering a value for cuvette size is optional and is for user information only
- When the necessary parameter values have been specified, a flashing “P” appears in the character space in the lower right corner of the LCD display indicating that the pulse button on the Gene Pulser Xcell System is active and that a pulse may be delivered
- Press the Pulse button to deliver a pulse. When the Pulse button is depressed, the LCD display will blank then show “Pulsing.” Upon completion, a tone will sound and the pulse measurements will be displayed on the Protocol Results screen (see Figure 3.7, Section 3.2.5)
- Use the Left and Right Arrow keys to toggle between the Protocol Results screen and the last Protocol Detail screen
- With the Protocol Detail screen on the LCD display, another pulse can be delivered using the same pulse parameters. To change the pulse conditions, press Enter; the cursor appears in the voltage parameter value. The parameters may be changed as described above
- To save the pulse parameters, see Section 3.2.6
- To review previously delivered pulses, see Section 3.7

3.2.4 Electroporation Using Square-Wave Pulses

See Section 4.2 for a discussion of electroporation using square-wave pulses. Use the Gene Pulser Xcell System to deliver square-wave pulses as follows:

- From the Home screen (Figure 3.2), press 3 or use the Up or Down Arrow keys to highlight “Square wave protocol,” then press Enter. The Square-Wave Protocol Detail screen appears (Figure 3.5)

- The following combination of parameters may be entered

Pulse length + Voltage
 Pulse length + Voltage + Number of pulses + Pulse interval

PROTOCOL DETAIL: SQUARE WAVE	
Voltage (V)	XXXX
Pulse length (msec)	XXX.XX
Number of pulses	1
Pulse interval (sec)	00.0
Cuvette (mm)	X

Fig. 3.5. Square-Wave Protocol Detail Screen. This screen shows the parameters that may be specified for square-wave electroporation. Entering the cuvette size is optional and is for user information only.

Electroporation using square-waves may be used to deliver a series of multiple pulses to the cells. This is specified by the parameter “Number of pulses.” The time between each pulse is specified as the “Pulse interval.” The default values for the number of pulses and pulse interval are 1 and 0, respectively; it is only necessary to enter other values if more than one pulse is to be delivered. See Section 4.2 for a discussion of pulse parameters.

The pulse parameters may be selected in any order. However, the set voltage will determine whether the high-voltage or the low-voltage circuit is to be used. Consequently, the set voltage will limit the ranges of the pulse length and pulse interval as indicated in Table 3.3. If values for the second and third parameters are chosen that are outside the range of the system, the values will default to the closest allowable values.

Table 3.3. Pulse length and pulse interval ranges for the high-voltage/low-capacitance circuit and the low-voltage/high-capacitance circuit of the Gene Pulser Xcell System for delivering a square-wave pulse.

	Voltage, V	Pulse Length, ms	Pulse Interval, sec	# Pulses (max)
LV Circuit*	10–500	0.05–100	0.1–10	10
HV Circuit	200–3,000	0.05–5	5–30	2

*Use of the low-voltage circuit requires that the CE module be in place.

- Use the Up and Down Arrow keys to scroll through and highlight the parameter value space for voltage, pulse length, number of pulses, or pulse interval. Use the alpha-numeric keypad to input the desired value, or use the Right and Left Arrow keys to increase or decrease the parameter value by the smallest allowable increment. Use the Delete or Clear keys to correct entries. When the desired value has been specified, press Enter. If a value outside the limits of the Gene Pulser Xcell System is selected, the value in the field will default to the closest permitted value. Entering a value for cuvette size is optional and is for user information only
- When the necessary parameter values have been specified, a flashing “P” appears in the character space in the lower right corner of the LCD display indicating that the pulse button on the Gene Pulser Xcell System is active and that a pulse may be delivered
- Press the Pulse button to deliver a pulse. When the Pulse button is depressed, the LCD display will blank then show “Pulsing.” Upon completion, a tone will sound and the pulse measurements will be displayed on the Protocol Results screen (see Figure 3.8, Section 3.2.5)
- Use the Left and Right Arrow keys to toggle between the Protocol Results screen and the last Protocol Detail screen

- With the Protocol Detail screen on the LCD display, another pulse can be delivered using the same pulse parameters. To change the pulse conditions, press Enter; the cursor appears in the voltage parameter value. The parameters may be changed as described above
- To save the pulse parameters, see Section 3.2.6
- To review previously delivered pulses, see Section 3.7

3.2.5 Results Screens

After delivering a pulse, the LCD displays the results on a Protocol Results screen. This screen shows the results in both graphic and tabular form. Figures 3.6, 3.7, and 3.8 show examples of the results from an exponential decay pulse, an exponential decay pulse in which the time constant was specified, and a square-wave pulse, respectively.

Results of the last 100 pulses as well as of the pulse parameters are stored in the Gene Pulser Xcell System memory and are accessible from the Data Management program (Section 3.7).

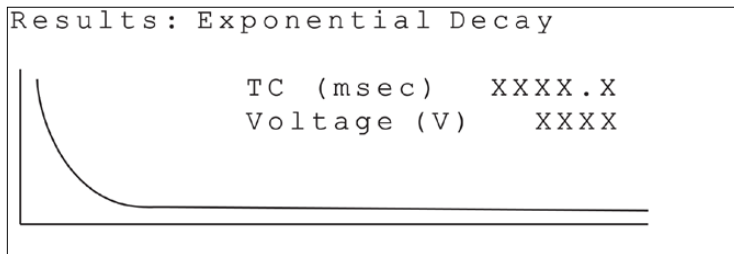

Fig. 3.6. Exponential Decay Protocol Results screen. The graph shows the exponential decay pulse. The table gives the calculated time constant (TC) and the delivered voltage (Voltage).

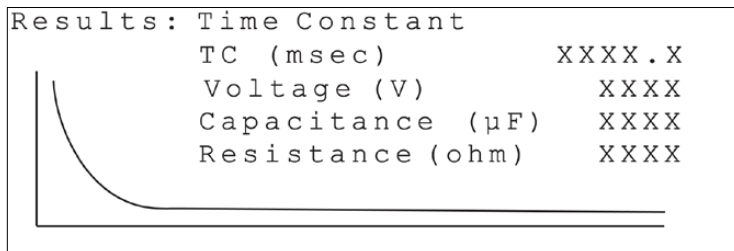

Fig. 3.7. Time Constant Protocol Results screen. The graph shows the exponential decay pulse. The table gives the delivered time constant (TC) and voltage (Voltage) as well as the selected capacitor (Capacitance) and resistor (Resistance).

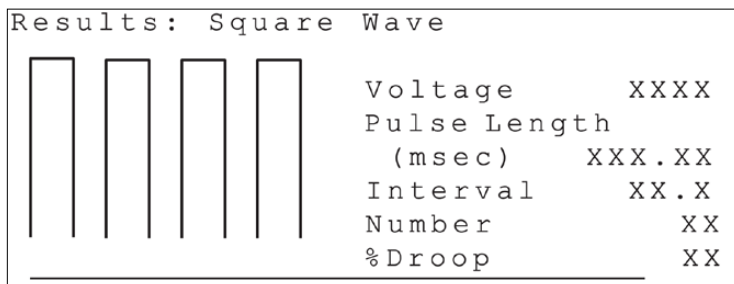

Fig. 3.8. Square-Wave Protocol Results screen. The graph shows the square-wave pulse. **Note:** The x-axis may not be to scale. The table shows the actual pulse length (Pulse Length), the delivered voltage (Voltage), the calculated droop (% Droop), and, when multiple pulses are given, the pulse interval (Interval) and the number of pulses (Number).

3.2.6 Saving a Program from Manual Operation

A protocol created in manual mode may be saved as a User Protocol as follows:

- Create a protocol as described in Section 3.2.2, 3.2.3, or 3.2.4
- With the Protocol Detail screen open, press Save
- The first User Directory screen will appear (Figure 3.9); the second line will read “Choose location for protocol”
- Use the Right and Left Arrow keys to toggle between the 2 User Directory screens. Press 1–12 or use the Up and Down Arrow keys to highlight the User Name under which to store the protocol. Press Enter to select the User Name. The User Protocols screen will appear (Figure 3.10); the second line will read “Choose location for protocol.” If it is necessary to create a new User Name, see Section 3.4.2
- Use the Right and Left Arrow keys to toggle between the two User Protocols screens. Press 1–12 or use the Up and Down Arrow keys to highlight a location for the new protocol. A protocol may be stored in a position without an entry (see Section 3.2.6A) or in a position with an entry (see Section 3.2.6B). If necessary, delete a User Protocol as described in Section 3.4.5
- To use the saved protocol, press Enter to view the Protocol Detail screen. Press the Pulse button to electroporate the sample

```

USER DIRECTORY
Choose location for protocol
 1. User1
 2. Labguy
 3. Malcom
 4. Smith
 5. Wesson
> 6.

```

Fig. 3.9. User Directory screen. This is an example of the first User Directory screen. Toggle between this screen and the second screen with Users 7–12 using the Left and Right Arrow keys. When purchased, the initial User Directory screen will have only numbers without any names.

```

USER PROTOCOLS: User1
Choose location for protocol
 1. CHO
 2. Monkey
 3. Human
 4.
 5.
> 6.

```

Fig. 3.10. User Protocols screen. This is an example of the first User Protocols screen. Toggle between this screen and the second screen with Protocols 7–12 using the Left and Right Arrow keys. When purchased, the initial User Protocols screen will have only numbers without any names.

3.2.6A Saving a Protocol in a Location without a Named User Protocol Entry

- With a User Protocols screen displayed on the LCD, press 1–12 or use the Up, Down, Left, and Right Arrows to highlight a User Protocol without an entry (e.g., positions 4, 5, or 6 on the screen in Figure 3.10)

- Press Enter to select the position
- Type in the name using the alpha-numeric keypad (alphabetic entries are the default); press Shift to toggle between alphabetic and numeric entries; the maximum length is 10 characters; to use the same key twice, advance the cursor using the Right Arrow Key, spaces are not allowed). Press Save or Enter. The protocol is saved in the location named on the User Protocols screen
- To use the saved protocol, press Enter to view the Protocol Detail screen. Press the Pulse button to deliver a pulse

3.2.6B Saving a Protocol in a Location with a Named User Protocol Entry

- With a User Protocols screen displayed on the LCD, press 1–12 or use the Up, Down, Left, and Right Arrows to highlight a User Protocol with a named entry (e.g., positions 1, 2, or 3 on the screen in Figure 3.10)
- Press Enter to select the position
- A Warning screen will appear asking whether you want to overwrite the selected User Protocol (Figure 3.11)

```

Do you want to overwrite the
protocol?
  YES                               NO

Press BACK or ENTER to return
to the previous screen.
Press the LEFT arrow then
ENTER to overwrite the name.

```

Fig. 3.11. Warning screen: overwrite protocol.

- The default selection is “No.” Press Enter if you do not want to overwrite the file. The program will return to the previous User Protocols screen
- Press the Left Arrow key to select “Yes,” then press Enter to overwrite the file. The User Protocol will have the same name and will contain all of the parameters specified in the new User Protocol. The program will return to the User Protocols screen with the cursor highlighting the location (number) of the selected User Protocol
- To use the saved protocol, press Enter to view the Protocol Detail screen. Press the Pulse button to deliver a pulse

3.3 Preset Protocols

The Gene Pulser Xcell System is preprogrammed with optimized settings for a number of commonly used bacterial, fungal, and mammalian cells. The settings are given in Table 3.4. The settings may also be viewed on the LCD display as described below (see Section 3.3.2). It is possible to change any of the parameters prior to pulsing a sample. While permanent changes cannot be made to any Preset Protocol, changes may be saved as a User Protocol (see Section 3.3.4).

3.3.1 Using a Preset Protocol (Quick Guide)

- From the Home Screen, press 4, then Enter to show the Preset Protocols screen
- Press 1–3 to choose between bacterial, fungal, or mammalian cells; press Enter to select the organism type and to show the list of organisms. For Bacterial and Mammalian Preset Protocols, use the Right and Left Arrow keys to toggle between the 2 screens
- Press the number next to the desired protocol to highlight it; press Enter to select and to show the Protocol Detail screen
- Press the Pulse button to electroporate the sample
- Press the Back key to return to the Protocol Detail screen and to deliver another pulse

3.3.2 Electroporation Using Preset Protocols

There are nine Preset Bacterial Protocols, six Preset Fungal Protocols, and 12 Preset Mammalian Protocols. These protocols are preprogrammed with the optimal parameters for the given organism. Use the Preset Protocols as follows:

- From the Home screen, press 4 or use the Up and Down Arrow keys to highlight “Preset Protocols,” then press Enter to select and to show the Preset Protocols screen (Figure 3.12)
- Press 1–3, or use the Up and Down Arrow keys, to highlight Bacterial, Fungal, or Mammalian Preset Protocols, then press Enter to select
- Use the alpha-numeric keypad or the Up and Down Arrow keys to scroll through the list of names. For the Bacterial and Mammalian Preset Protocols, use the Right and Left Arrow keys to toggle between the 2 screens. When the number corresponding to the desired name is highlighted, press Enter to select and to view the Protocol Detail Screen showing the electroporation parameters for that protocol. A flashing “P” in the character space in the lower right corner of the LCD display indicates that the Pulse button is active
 - For example, from the Preset Protocols screen, press 3 to highlight “Mammalian,” then press Enter to select and to bring up the first Preset Mammalian Protocols screen with the names of 6 preset mammalian protocols (Figure 3.13). Press the Right and Left Arrow keys to toggle between the 2 Mammalian Preset Protocols screens. Use the alpha-numeric keypad or the Up and Down Arrow keys to scroll through the list of names. When the desired name on the Mammalian Preset Protocols screen is highlighted, press Enter to select that protocol and to view the Protocol Detail Screen showing the electroporation parameters for that protocol. For example, from the Mammalian Preset Protocols screen, press 1, then Enter to bring up the Protocol Detail Screen for CHO cells in a 2-mm cuvette (Figure 3.14)
- Press the Pulse button to deliver a pulse. When the Pulse button is depressed, the LCD display will blank then show “Pulsing.” Upon completion, a tone will sound and the pulse measurements will be displayed on the Protocol Results screen (see Section 3.2.5)
- Use the Left and Right Arrow keys to toggle between the Protocol Results screen and the last Protocol Detail screen

- With the Protocol Detail screen on the LCD display another pulse can be delivered using the same pulse parameters. To change the pulse conditions, press Enter; the cursor appears in the voltage parameter value. The parameters may be changed as described in Section 3.3.3
- To review previously delivered pulses, see Section 3.7

```

PRESET  PROTOCOLS

 1 . B a c t e r i a l
 2 . F u n g a l
 3 . M a m m a l i a n

```

Fig. 3.12. Preset Protocols Screen. There are Preset protocols for bacteria, fungi, and mammalian cells. Use this screen to make a selection from the list.

```

PRESET  PROTOCOLS : MAMMALIAN

 1 . C H O
 2 . C o s 7
 3 . M 3 T 3
 4 . 2 9 3
 5 . H e L a
 > 6 . B H K 2 1

```

```

PRESET  PROTOCOLS : MAMMALIAN

 7 . A 5 4 9
 8 . C V 1
 9 . K 5 6 2
10 . H L 6 0
11 . J u r k a t
>12 . H u T 7 8

```

Fig. 3.13. Mammalian Preset Protocols Screens. Protocols are provided for 12 mammalian cell lines. The names of the first six are shown on Screen 1; the names of the second six are shown on Screen 2.

```

PROTOCOL DETAIL : C H O

Voltage (V)                160
Pulse length (msec)        15.00
Number of pulses           1
Pulse interval (sec)       00.0
Cuvette (mm)              2
                           P

```

Fig. 3.14. Protocol Detail Screen for CHO cells in the Preset Protocols menu.

Table 3.4. Optimized settings found in the Preset Protocols function of the Gene Pulser Xcell System.

Preset Protocol Designation	Cells	Pulse Type	PL, ms	C, μ F	PC, Ω	Voltage, V	Cuvette, cm	Cell Volume, μ l
Mammalian 1	CHO	Square wave	15	–	–	160	0.2	100
Mammalian 2	COS7	Square wave	20	–	–	110	0.2	100
Mammalian 3	3T3	Exponential decay	–	500	∞	160	0.2	100
Mammalian 4	293	Square wave	25	–	–	110	0.2	100
Mammalian 5	HeLa	Exponential decay	–	500	∞	160	0.2	100
Mammalian 6	BHK21	Square wave	25	–	–	140	0.2	100
Mammalian 7	A549	Square wave	10	–	–	150	0.2	100
Mammalian 8	CV1	Square wave	25	–	–	100	0.2	100
Mammalian 9	K562	Exponential decay	–	1,000	∞	155	0.2	100
Mammalian 10	HL60	Square wave	25	–	–	140	0.2	100
Mammalian 11	Jurkat	Exponential decay	–	1,000	∞	140	0.2	100
Mammalian 12	HuT78	Square wave	25	–	–	130	0.2	100
Bacterial 1	<i>E. coli</i>	Exponential decay	–	25	200	1,800	0.1	20
Bacterial 2	<i>E. coli</i>	Exponential decay	–	25	200	2,500	0.2	20–40
Bacterial 3	<i>E. coli</i>	Exponential decay	–	25	200	3,000	0.2	20–40
Bacterial 4	<i>A. tumefaciens</i>	Exponential decay	–	25	200	2,400	0.1	20
Bacterial 5	<i>P. aeruginosa</i>	Exponential decay	–	25	200	2,500	0.2	100
Bacterial 6	<i>S. aureus</i>	Exponential decay	–	25	100	2,900	0.2	50
Bacterial 7	<i>B. cereus</i>	Exponential decay	–	50	200	1,000	0.2	100
Bacterial 8	<i>S. pyogenes</i>	Exponential decay	–	25	200	2,100	0.2	200
Bacterial 9	<i>L. plantarum</i>	Exponential decay	–	25	400	2,000	0.2	40
Fungal 1	<i>S. cerevisiae</i>	Exponential decay	–	25	200	1,500	0.2	40
Fungal 2	<i>S. cerevisiae</i>	Exponential decay	–	25	200	2,500	0.4	80
Fungal 3	<i>S. pombe</i>	Exponential decay	–	25	200	2,300	0.2	40
Fungal 4	<i>C. albicans</i>	Exponential decay	–	25	200	1,500	0.2	40
Fungal 5	<i>P. pastoris</i>	Exponential decay	–	25	200	2,000	0.2	40
Fungal 6	<i>D. discoideum</i>	Square wave	1.0	–	–	1,000	0.4	800 2 pulses

3.3.3 Modifying Preset Protocol Parameters

The parameters for a Preset Protocol may be changed as follows:

- From the Protocol Detail screen, press the Up or Down Arrow keys to highlight the value for 1 of the parameter settings (voltage, capacitance, or resistance for exponential decay pulses; voltage or time constant for time constant mode; pulse length, voltage, number of pulses, or pulse interval for square-wave pulses). (**Note:** The waveform cannot be changed in the Preset Protocols Mode.) When the desired parameter is selected, use the alpha-numeric keypad to input the new value. Alternatively, use the Right and Left Arrow keys to incrementally increase or decrease, respectively, the parameter value. Use the Delete or Clear keys to correct entries. When the correct value has been specified, press Enter. If a value outside the limits of the Gene Pulser Xcell System is selected, the value in the field will default to the closest permitted value. Use the Up and Down Arrow keys to select other parameter values to be changed, then use the alpha-numeric keypad or the Left and Right Arrow keys to enter the desired value
- A pulse may be delivered when appropriate parameters have been entered in the Protocol Detail screen and the character space at the lower right of the LCD display is flashing “P”
- To return to the last Protocol Detail screen, press the Back key or the Left Arrow key. Another pulse may be delivered using the same parameters shown on the LCD display. To return to the Protocol Results Screen, press the Right Arrow key. (**Note:** Returning to the Protocol Detail screen returns to the modified parameters. To return to the Preset Protocol, press the Back key again to return to the Preset Protocols screen. This will remove any changes made.)
- To change the pulse conditions, with the Protocol Detail screen on the LCD display, press Enter; the cursor appears in the voltage parameter value. The parameters may be changed as described above

- To review previously delivered pulses, see Section 3.8

3.3.4 Saving Changes to Preset Protocols

Changes to a Preset Protocol may be saved as a User Protocol as follows:

- Change the Preset Protocol as described in Section 3.3.3
- With the Protocol Detail screen open, press Save
- The first User Directory screen will appear (Figure 3.9); the second line will read “Choose location for protocol”
- Use the Right and Left Arrow keys to toggle between the 2 User Directory screens. Press 1–12 or use the Up and Down Arrow keys to highlight the User Name under which to store the protocol. Press Enter to select the User Name. The User Protocols screen will appear (Figure 3.10); the second line will read “Choose location for protocol.” If it is necessary to create a new User Name, see Section 3.4.2
- Use the Right and Left Arrow keys to toggle between the 2 User Protocols screens. Press 1–12 or use the Up and Down Arrow keys to highlight a location for the new protocol. A protocol may be stored in a position without an entry (see Section 3.3.6A) or in a position with an entry (see Section 3.2.6B). If necessary, delete a User Protocol as described in Section 3.4.5
- To use the saved protocol, press Enter to view the Protocol Detail screen. Press the Pulse button to deliver a pulse

3.4 User Protocols

User Protocols enable users to store their own protocols for the Gene Pulser Xcell System. Up to 144 electroporation protocols may be programmed and stored (12 users [User Names in the User Directory] each with 12 protocols per user [User Protocols]).

A new User Protocol may be created by:

- Creating a new protocol by entering all new parameters in manual mode (Sections 3.2.2, 3.2.3, and 3.2.4)
- Modifying (editing) a Preset Protocol (Section 3.3.3)
- Creating a new protocol as a User Protocol (Section 3.4.3)
- Modifying (editing) an existing User Protocol (Section 3.4.4)

Protocols created or modified in the User Protocols menu may be used without being saved (Section 3.4.4).

3.4.1 Using a User Protocol (Quick Guide)

- From the Home screen, press 5, then Enter to open the User Protocols menu and to show the first User Directory screen. Use the Right and Left Arrow keys to toggle between the 2 screens
- Press 1–12 to highlight the desired name; press Enter to select that name and to show the first User Protocols screen. Use the Right and Left Arrow keys to toggle between the 2 screens
- Press 1–12 to highlight the desired protocol name; press Enter to select that protocol and to show the Protocol Detail screen. The Pulse button on the Gene Pulser Xcell System is now active

- Press the Pulse button to electroporate the sample
- Press the Back key to return to the Protocol Detail screen and to deliver another pulse

3.4.2 Creating a New User Name

A new User Name can be created when the space adjacent to that number on the User Directory screen is clear (Figure 3.15). If it is necessary to delete a User Name or a User Protocol, see Section 3.4.5.

Create a new User Name in the User Name screen as follows:

- From the Home screen (Figure 3.2), press 5 or use the Up and Down Arrow keys to highlight “User Protocols,” then press Enter to view the User Directory screen (Figure 3.15)
- Use the Right and Left Arrow keys to toggle between the 2 User Directory screens. Press 1–12 or use the Up or Down Arrow keys to highlight a position without an entry. Press Enter to select the position
- Use the alpha-numeric keypad to type in the desired User Name. A name can have up to 10 characters. Press Save when complete. The new User Name is saved

3.4.3 Creating a New User Protocol

This section describes how to create a new User Protocol from the User Protocols screen and save the protocol. A new User Protocol can be created when the space adjacent to that number on the User Protocol screen is clear (Figure 3.16). Section 3.4.4 describes how to edit (change) an existing User Protocol and save the changes.

- To enter the User Protocols screen from the Home screen (Figure 3.2):
 - Press 5 or use the Up and Down Arrow keys to highlight “User Protocols,” then press Enter to view the first User Directory screen (Figure 3.15)
 - Use the Right and Left Arrow keys to toggle between the 2 User Directory screens. Press 1–12 or use the Up and Down Arrow keys to highlight the number corresponding to the desired User Name
 - Press Enter to select the name and to view the User Protocols screen (Figure 3.16)
- Press 1–12 or use the Up, Down, Left, and Right Arrow keys to highlight a User Protocol without an entry. If necessary, delete a User Protocol as described in Section 3.4.5. Press Enter to view the Select Method screen (Figure 3.17)
- Press 1–3 or use the Up and Down Arrow keys to highlight the number corresponding to delivering an exponential decay pulse (Exponential protocol), an exponential decay pulse specifying the time constant (Time constant protocol), or a square-wave pulse (Square wave protocol). Press Enter to make a selection and to view the appropriate Protocol Detail screen

```
USER DIRECTORY

1.User1
2.Labguy
3.Malcom
4.Smith
5.Wesson
>6.
```

```
USER DIRECTORY

<7.
8.
9.
10.
11.
12.
```

Fig. 3.15. User Directory screens.

```
USER PROTOCOLS: User1

1.CHO
2.Monkey
3.Human
4.
5.
>6.
```

Fig 3.16. User Protocols screen.

```
SELECT METHOD

1.Exponential protocol
2.Time constant protocol
3.Square wave protocol
```

Fig. 3.17. Select Method screen.

- When “Exponential protocol” is selected, the Exponential Decay Protocol Detail screen appears (Figure 3.18) with the User Name on the first line

```

Labguy:          Protocol:

Voltage (V)                XXXX
Capacitance (µF)           XXXX
Resistance (ohm)            XXXX
Cuvette (mm)                X
    
```

Fig. 3.18. Exponential Decay Protocol Detail screen.

- When “Time constant protocol” is selected, the Time Constant Protocol Detail screen appears (Figure 3.19) with the User Name on the first line

```

Labguy:          Protocol

Voltage (V)                XXXX
Time constant (msec)       XXXX.X
Cuvette (mm)                X
    
```

Fig. 3.19. Time Constant Protocol Detail screen.

- When “Square wave protocol” is selected, the Square-Wave Protocol Detail screen appears (Figure 3.20) with the User Name on the first line

```

Labguy:          Protocol:

Voltage (V)                XXXX
Pulse length (msec)        XXX.XX
Number of pulses            1
Pulse interval (sec)       00.0
Cuvette (mm)                X
    
```

Fig. 3.20. Square-Wave Protocol Detail screen.

- Use the Up and Down Arrow keys to scroll through the parameter value spaces on the appropriate Protocol Detail screen. Use the alpha-numeric keypad to input the desired value, or use the Right and Left Arrow keys to incrementally increase or decrease the parameter value. Use the Delete or Clear keys to correct entries. When the desired value has been specified, press Enter. If a value outside the limits of the Gene Pulser Xcell System is selected, the value in the field will default to the closest permitted value (see Tables 3.1, 3.2, and 3.3). Entering a value for cuvette size is optional and is for user information only
- When the necessary parameter values have been specified, a flashing “P” appears in the character space in the lower right corner of the LCD display indicating that the pulse button on the Gene Pulser Xcell System is active and that a pulse may be delivered

- Press the Pulse button to deliver a pulse. When the Pulse button is depressed, the LCD display will blank then show “Pulsing.” Upon completion, a tone will sound and the pulse measurements will be displayed on the Protocol Results screen (see Section 3.2.5)
- To save the pulse parameters, with the Protocol Detail screen on the LCD, press Save
- The User Protocols screen will appear with the cursor flashing on the first character space of the selected position. Type in the name using the alpha-numeric keypad (alphabetic entries are the default; press Shift to toggle between alphabetic and numeric entries). Press Save or Enter when complete. The protocol is saved in the location named in the User Protocols screen

3.4.4 Modifying a User Protocol

A User Protocol may be modified (changed) as follows:

- To enter the User Protocols screen from the Home screen (Figure 3.2)
 - Press 5 or use the Up and Down Arrow keys to highlight “User Protocols,” then press Enter to view the first User Directory screen (Figure 3.15)
 - Use the Right and Left Arrow keys to toggle between the 2 User Directory screens. Press 1–12 or use the Up and Down Arrow keys to highlight the desired User Name. Press Enter to select the name and to view the first User Protocols screen (Figure 3.16)
- Press 1–12 or use the Up, Down, Left, and Right Arrow keys to highlight the desired User Protocol to be edited. Press Enter to view the Protocol Detail screen
- Use the Up and Down Arrow keys to highlight the value of the first parameter to be changed. Use the alpha-numeric keypad to enter a new value. Alternatively, use the Right and Left Arrow keys to incrementally increase or decrease, respectively, the parameter value. Use the Delete or Clear keys to correct entries
- When the desired value has been specified, press Enter. If a value outside the limits of the Gene Pulser Xcell is entered, the value in the field will default to the closest permitted value
- Use the Up and Down Arrow keys to highlight the parameter values to be changed and repeat the previous two steps. The Pulse button becomes active when the necessary parameters have been entered into the Protocol Detail screen. The edited protocol may be used without saving
- To save the edited protocol, with the Protocol Detail screen on the LCD, press Save. A warning screen will appear asking if you want to overwrite the protocol (Figure 3.21). The default selection is “No”
- If you do not want to overwrite protocol name press the Back key to return to the Protocol Detail screen. Press Enter to return to the User Directory and to choose a new location (Figure 3.9). See Section 3.2.6 for instructions on selecting a location for the new protocol
- To overwrite the protocol, press the Left Arrow key to select “Yes,” then press Enter to overwrite the file. The User Protocol will have the same name as the old file and will contain the parameters specified in the new protocol. The LCD will display the User Protocols screen with the cursor highlighting the location (number) of the protocol

```
Do you want to overwrite the
protocol?

  YES                               NO
Press BACK or ENTER to return
to the previous screen.
Press the LEFT arrow then
ENTER to overwrite the name.
```

Fig. 3.21. Warning screen: overwrite protocol.

3.4.5 Deleting a User Name and a User Protocol

Before a User Name may be deleted, it is necessary to first delete all of the User Protocols under that name.

Delete a User Protocol as follows:

- To enter the User Protocols screen from the Home screen (Fig 3.2)
 - Press 5 or use the Up and Down Arrow keys to highlight “User Protocols,” then press Enter to view the first User Directory screen (Figure 3.15). Use the Right and Left Arrow keys to toggle between the 2 User Directory screens
 - Enter the number corresponding to the desired User Name or use the Up and Down Arrow keys to highlight the desired User Name
 - Press Enter to select the name and to view the User Protocols screen
- Use the alpha-numeric keypad or the Up and Down Arrow keys to select the position with the protocol to be deleted
- Press the Delete key. A warning screen will appear asking whether you want to delete the selected User Protocol (Figure 3.22). The default selection is “No”
 - If you do not want to delete the Protocol, press Back or Enter. The program will return to the previous User Protocols screen
 - To delete the Protocol, press the Left Arrow key to select “Yes,” then press Enter. The User Protocol name as well as all of the parameters under that User Protocol is deleted. The program will return to the User Protocols screen with the selected User Protocol deleted

```
Do you want to delete the
protocol?

  YES                               NO
Press BACK or ENTER to return
to the previous screen.
Press the LEFT arrow then
ENTER to delete the name.
```

Fig. 3.22. Warning screen: delete protocol.

Delete a User Name as follows:

- With the User Directory screen on the LCD, press the Up or Down Arrow keys or use the alpha numeric keypad to select the name to be deleted. Use the Left and Right Arrow keys to toggle between the 2 User Directory screens
- Press the Delete key. If there are no protocols in the User Name file, a warning screen will appear asking whether you want to delete the selected User Name (Figure 3.23). The default selection is “No”
 - If you do not want to delete the file, press Enter. The program will return to the User Directory screen
 - To delete the User Name, press the Left Arrow key to select “Yes,” then press Enter. The program will return to the User Directory with the selected User Name deleted
- If there are protocols in the User Name file, the following screen will appear: “All User Protocols under this name must be deleted before this user name can be deleted.” Follow the steps above for deleting the User Protocols

```

Do you want to delete the user
protocol?

      YES                NO
Press BACK or ENTER to return
to the previous screen.
Press the LEFT arrow then
ENTER to delete the name.
  
```

Fig. 3.23. Warning screen: delete name.

3.4.6 Changing a User Name or a User Protocol Name

Change a User Name or a User Protocol name as follows:

- Choose the User Name or User Protocol to rename from the User Directory screen or the User Protocols screen, respectively
- Press the Clear key. A warning screen will appear asking whether you want to change the selected name (Figure 3.24). The default selection is “No”
 - If you do not want to change the name, press Enter. The program will return to the corresponding User Directory or User Protocols screen
 - To change the name, press the Left Arrow key to select “Yes,” then press Enter. The previous screen will appear but with the selected name cleared and with the cursor on the field for the new name. Use the alpha-numeric keypad to type in the desired new name. A name can have up to 10 characters. Use the Shift key to toggle between alphabetic and numeric characters. Press Save when complete. The new name is saved

```

Do you want to change the
name?

  YES                               NO
Press BACK or ENTER to return
to the previous screen.
Press the LEFT arrow then
ENTER to change the name.

```

Fig. 3.24. Warning screen: name change.

3.5 Last Pulse

From the Home screen (Figure 3.2), press 6 or use the Up or Down Arrow keys to select “Last pulse,” then press Enter to display the Protocol Detail screen showing the last pulse delivered. This is also accessible after the instrument has been turned off and restarted.

3.6 Optimize Operation

The Optimize mode allows the user to program a voltage that incrementally increases or decreases when the Right and Left Arrow keys are pressed. This mode operates similarly to Manual Protocols (Section 3.2.2, 3.2.3, and 3.2.4) but requires that a voltage increment be specified.

- Access this screen from the Home screen (Figure 3.2) by pressing 7 or use the Up or Down Arrow keys to highlight “Optimize” then press Enter. The Select Method screen appears (Figure 3.17)
- Press 1–3 or use the Up and Down Arrow keys to highlight the number corresponding to optimizing voltage by delivering (i) an exponential decay pulse (“Exponential protocol”), (ii) an exponential decay pulse specifying the time constant (“Time constant protocol”), or (iii) a square-wave pulse (“Square wave protocol”). Press Enter to make a selection and to view the appropriate Optimize screen

```

SELECT METHOD

  1.Exponential protocol
  2.Time constant protocol
  3.Square wave protocol

```

Fig. 3.17. Select Method screen.

- When “Exponential protocol” is selected, the Exponential Decay Protocol Optimize screen appears (Figure 3.25)
- When “Time constant protocol” is selected, the Time Constant Protocol Optimize screen appears (Figure 3.26)
- When “Square wave protocol” is selected, the Square-Wave Protocol Optimize screen appears (Figure 3.27)

```

OPTIMIZE: EXPONENTIAL DECAY

Starting voltage (V)      XXXX
Increment (V)            XXX
Capacitance (µF)        XXXX
Resistance (ohm)         XXXX
Cuvette (mm)             X

```

Fig. 3.25. Exponential Decay Protocol Optimize screen.

```

OPTIMIZE: TIME CONSTANT

Starting voltage (V)      XXXX
Increment (V)            XXX
Time constant (msec)     XXXX.X
Cuvette (mm)             X

```

Fig. 3.26. Time Constant Protocol Optimize screen.

```

OPTIMIZE: SQUARE WAVE

Starting voltage (V)      XXXX
Increment (V)            XXX
Pulse length (msec)     XXX.XX
Number of pulses         1
Pulse interval (sec)    XX.X
Cuvette (mm)             X

```

Fig. 3.27. Square-Wave Protocol Optimize screen.

- Use the Up and Down Arrow keys to scroll through the parameter value spaces on the screen. When the desired parameter space is highlighted, use the alpha-numeric keypad to input the desired value (only numeric entries are permitted). Alternatively, use the Right and Left Arrow keys to incrementally increase or decrease the parameter value. Use the Delete or Clear keys to change the value. When the desired value has been specified, press Enter. If a value outside the limits of the Gene Pulser Xcell System is selected, the value in the field will default to the closest permitted value
- When the necessary parameter values have been specified, a flashing “P” appears in the character space in the lower right corner of the LCD display indicating that the pulse button on the Gene Pulser Xcell System is active and that a pulse may be delivered

- To use the program
 - Press Pulse to deliver the pulse at the specified voltage
 - After the pulse, the Protocol Results screen is displayed; use the Left and Right Arrow keys to toggle between the Protocol Results screen and the last Protocol Detail screen
 - From the Protocol Detail screen, another pulse at the same voltage may be delivered by pressing Pulse. Press Enter to bring the cursor on the screen; the cursor will appear at the right character space of the first parameter (the voltage). To increase the voltage by the specified increment value, press the Right Arrow key; to decrease the voltage by the specified value, press the Left Arrow key. Press Pulse to deliver another pulse

3.7 Data Management

This section of the program allows the user to view the parameter values and output of the last 100 pulses. Data for each pulse are presented on a single screen; examples are given below. Each data set includes the date and time of the pulse, an identifier for how the pulse was programmed, the set parameters, and the delivered pulse. The pulses are displayed in chronological order or in reverse chronological order and are logged by date and time. Check that the date and time are correct under User Preferences (Section 3.9, Setting the Clock). Selecting chronological order displays the earliest pulse in the data bank or, if a specific date was selected, the earliest pulse from the specified date. Selecting reverse chronological order displays the latest pulse in the data bank or, if a specific date was selected, the last pulse from the specific date. This is a read-only file. No changes are permitted to this file.

- From the Home screen (Figure 3.2) press 8 or use the Up and Down Arrow keys to highlight “Data Management,” then press Enter to display the Data Management screen (Figure 3.28)
- Press 1–4, then Enter to select the data to view. Selecting 3 or 4 brings up a Date screen (Figure 3.29). Use the keypad to enter a date, then press Enter to select that date and to view the data. If no data were collected on that date, a screen will appear indicating that no data are present for that date

```

What data do you want to view?
All data
 1.Reverse chronological order
 2.Chronological order

Data from a specific date
 3.Chronological order
 4.Reverse chronological order

```

Fig. 3.28. Data Management screen.

```

From what date do you want
to view data?

Month   MM
Date    DD
Year    YY

```

Fig. 3.29. Date screen.

Note: This is the default screen with the default clock preference set as MM/DD/YY; if the user changes the clock preference to DD/MM/YY, the order on the Date screen is Date, Month, Year.

- Press the Left and Right Arrow keys to view earlier and later pulse data, respectively. Press the Back key to return to the Data Management screen

Data screens contain the following information:

Line 1: Date and time
 Line 2: Identification of how pulse was programmed (e.g., Manual, Preset, User)
 Line 3: Type of pulse
 Lines 4–8: Pulse conditions

The following are examples of data screens (Figure 3.30). It is not possible to edit a Data screen.

Data Screen (User Protocol, Square-Wave)

Data output	12-12-01	20:20
User 11	Protocol 11	
	Settings	Output
V	1,230	1,230
PL (msec)	123.00	123.00
#P	12	12
PI (sec)	12.3	12.3
%droop	12	12

Data Screen (Manual Mode, Exponential Decay)

Data output	12-12-01	20:21
Manual exponential		
	Settings	Output
V	1,230	1,230
C (µF)	1,230	1,230
R (ohm)	1,000	1,000
TC (msec)		111.1
Cuvette (mm)	1	

Data Screen (Manual Mode, Time Constant)

Data output	12-12-01	20:22
Manual time constant		
	Settings	Output
V	1,230	1,230
TC (msec)	1,234.5	1,234.5
Cuvette (mm)	1	

Data Screen (Standard Protocol, *S. pombe* Setting)

Data output	12-12-01	20:23
Std Protocol:	<i>S.pombe</i>	
	Settings	Output
V	2,000	2,047
C (µF)	25	25
R (ohm)	200	200
TC (msec)		5.1
Cuvette (mm)	2	2

Fig. 3.30. Examples of data screens.

3.8 Measurements

This program allows the user to measure the resistance of a sample prior to pulsing in the Gene Pulser Xcell System and to measure the values of the capacitors in a Capacitance Extender attached to the Gene Pulser Xcell System.

- From the Home screen, press 9 or use the Up and Down Arrow keys to highlight “Measurements,” then press Enter to view the Measurements Screen (Figure 3.31)

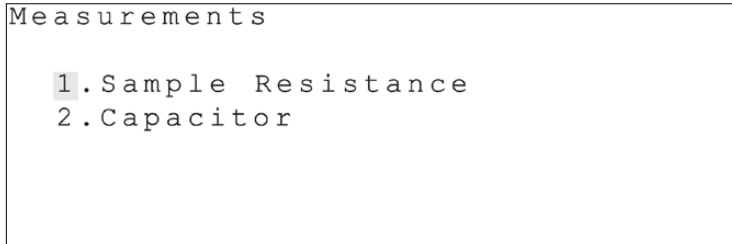

Fig. 3.31. Measurements screen.

3.8.1 Sample Resistance Measurements

Placing a cuvette containing a sample in the shocking chamber will allow the Gene Pulser Xcell System to measure the sample resistance. The resistance determination is accurate for samples having a resistance between five and 1,100 Ω . Samples with a resistance less than five ohms will show “5 Ω .” Samples with a resistance greater than 1,100 Ω will show “>1,100 Ω .”

- When the Measurements screen (Figure 3.31) is selected, the number 1, corresponding to “Sample Resistance” is highlighted as the default choice. Press Enter to view the Sample Resistance screen. If the number 1 on the Measurements screen is not highlighted, press 1 or use the Up or Down Arrow keys to highlight, then press Enter to select. The Sample Resistance screen appears (Figure 3.32)

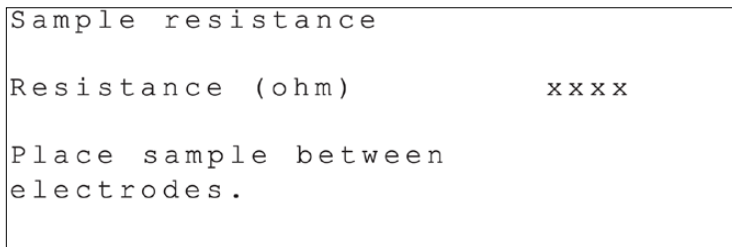

Fig. 3.32. Sample Resistance screen.

- Place a sample between the electrodes to allow the Gene Pulser Xcell System to monitor sample resistance. Close the top of the ShockPod and press Enter. The sample resistance is displayed on the LCD screen. The display range is 5–1,100 Ω

3.8.2 Calibration and Measurement of Capacitors in the CE Module

Because electrolytic capacitors change value slowly over time, to keep the instrument within its original specifications, the capacitors should be calibrated approximately every one to three months or whenever there is concern about the accuracy of the capacitors. The Capacitor Measurement function gives the user a more accurate determination of the capacitor values in the unit by making a measurement of the capacitors in the units. Capacitor calibration and measurement may be performed as follows:

- Unplug the ShockPod cables from the Gene Pulser Xcell System. Connect the CE module to the Gene Pulser Xcell System
- From the Measurements screen, press 2 or use the Up and Down Arrow keys to highlight “Capacitor,” then press Enter to display the Capacitor Measurement screen (Figure 3.33)
- To calibrate the capacitors, press the decimal point (.) on the alpha-numeric keypad. The Gene Pulser Xcell main unit will begin calibrating the capacitors in both the CE module and the Gene Pulser Xcell main unit. Calibration will take about 2 minutes. At the completion of the test, 12 numbers will be displayed at the bottom of the screen. The numbers on the top row and the first 3 on the bottom row are the actual values of the capacitors in the CE module. These capacitors are used in combination to set the capacitance in the exponential decay and time constant modes. When pulsing using the low-voltage circuit in square-wave mode, all of the capacitors from the CE module are used together; when pulsing using the high voltage circuit in square-wave mode, the 50- μ F capacitor in the Gene Pulser Xcell main unit is used
- To measure a specific capacitance, with the Capacitor Measurement screen on the LCD, use the alpha-numeric keypad to type in a capacitance value to be measured. Alternatively, use the Right and Left Arrow keys to increase or decrease, respectively, the capacitance values. Press Enter, then press Pulse. The actual capacitance value appears on the Measured Capacitance line. (No sample should be in place and no pulse occurs during this process)

```

Capacitor measurement
Capacitance ( $\mu$ F)           x x x x
Measured capacitance ( $\mu$ F)   x x x x

```

Fig. 3.33. Capacitor Measurement screen.

3.9 User Preferences

- From the Home screen, press 10 or use the Up or Down Arrow keys to highlight “User preferences,” then press Enter to display the User Preferences Screen (Figure 3.34)

```

User Preferences
1.Clock
2.Screen intensity
3.Sleep function

```

Fig. 3.34. User Preferences screen.

3.9.1 Setting the Clock

This section of the program allows the user to select how the date is presented, to enter a correct date, and to enter the correct time. The default setting for the date is Month/Date/Year; this may be changed to Date/Month/Year. The clock is a 24-hour clock.

- When the User Preferences screen (Figure 3.34) is selected, the number 1, corresponding to “Clock” is highlighted as the default choice. Press Enter to view the Set Clock screen. If the number 1 on the User Preferences screen is not highlighted, press 1 or use the Up or Down Arrow keys to highlight, then press Enter to select. The Set Clock screen appears (Figure 3.35)

```

Set clock

PREFERENCE      MM/DD/YY  DD/MM/YY
DATE            XX/XX/XX  XX/XX/XX
TIME           XX:XX
  
```

Fig. 3.35. Set Clock screen.

Note: The default setting is MM/DD/YY.

- Press the Left or Right Arrow keys to toggle between MM/DD/YY and DD/MM/YY. Press Enter to make a selection and to bring the cursor to the field below the choice where entries can be made
- If no change in the date is needed, press Enter again. Use the keypad to type in the date or time (only numeric entries are permitted). “0” must be typed to specify numbers 1–9 in all fields (i.e., 01–09). Use the Delete and Clear keys to correct entries. Press Enter when complete. The cursor will move to the field for entering a new time (XX:XX)
- If no change in the time is needed, press Save. Otherwise, use the alpha-numeric keypad to enter a new time. The clock is a 24-hour clock. Press Save when complete and return to the User Preferences screen

3.9.2 Adjusting the Screen Intensity

- From the User Preferences screen press 2 or use the Up and Down Arrow keys to select “Screen intensity,” then press Enter. The LCD Brightness screen appears (Figure 3.36)

```

LCD BRIGHTNESS

Press UP/DOWN arrow keys
to change the brightness of
the LCD display.
Press ENTER to select.
  
```

Fig. 3.36. LCD Brightness screen.

- Press the Up and Down Arrow keys to increase or decrease the screen brightness, respectively
- Press Enter to select. The LCD display returns to the User Preferences screen

3.9.3 Sleep Function Setting

The sleep function is an energy-saving mode of operation, designed to maximize the life of the battery and the LCD screen. The default setting causes the LCD display to turn off after 30 min of inactivity. Pressing any alpha-numeric key will restore the last screen displayed and return the Gene Pulser Xcell System to its former operating status. The user may change the time before the instrument enters sleep mode using the Sleep Function Setting.

- From the User Preferences screen press 3 or use the Up or Down Arrow keys to highlight “Sleep function,” then press Enter to select and to view the Sleep Function screen (Figure 3.37)

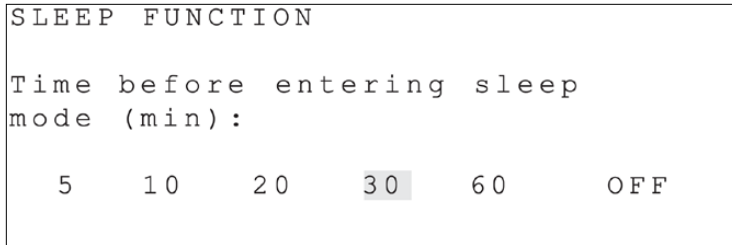

Fig. 3.37. Sleep Function screen.

- Use the Right and Left Arrow keys to change the time before the LCD enters sleep mode
- Press Enter to select. The LCD returns to the User Preferences screen

3.10 The Pulse Trac System

The Gene Pulser Xcell System uses the Pulse Trac waveform delivery system to generate the most accurate exponential decay pulses possible for optimal cell transformation. Pulse Trac accurately calculates the time constant and amplitude of each pulse based on what is actually delivered to the sample. However, more importantly, the Pulse Trac system compensates for amplitude changes caused by varying sample resistances and improves the accuracy of the low-voltage capacitors. This provides the following:

- Sample conductivity measurement integrated with pulse output for true waveform delivery for samples with resistance in the 10–1,000 Ω range
- Internal calibration and circuit monitoring program for accurate pulse delivery throughout the lifetime of the unit
- Time constant and voltage amplitude measurements to allow pulse delivery verification

3.10.1 Pulse Trac System Description

The Pulse Trac system monitors and adjusts for the internal system resistance used to limit current and sample resistance in the cuvette. Sample resistance depends on its conductivity, the distance between the electrodes in the cuvette, and the volume of medium within the cuvette. Pulse Trac circuitry monitors the resistance of the sample and delivers the desired voltage regardless of sample volume or conductivity. When you are optimizing electroporation with the Pulse Trac system, the electrical variables are controlled with exacting precision so that your results reflect only the biological variables in your experimental design. This Pulse Trac diagnostic algorithm examines the complete electrical circuit and electronically selects the right combination of capacitors to deliver the most accurate and reproducible pulse for optimal and consistent electroporation over the lifetime of the unit.

3.10.2 Pulse Trac Diagnostic Algorithm

This test algorithm tests and selects the optimal capacitor circuit of the Gene Pulser Xcell System and the CE module in the range of 25–3,275 μF . This is the key bank of capacitors used in low-voltage/high-capacitance precision pulse delivery. The test algorithm tightens the already rigorous capacitor tolerance from ± 20 to $\pm 10\%$ (other unit designs can have a capacitor variance as high as $\pm 40\%$) in the 200–1,075 μF range. The high voltage capacitors in the Gene Pulser Xcell System are not part of this system since they are preselected to the same 10% tolerance that this test algorithm provides.

The Pulse Trac test algorithm is activated upon startup of the Gene Pulser Xcell System when the Capacitor Extender module is installed.

Section 4 Overview of Electroporation Theory

Electroporation is a physical process in which cells are exposed to a high-voltage electric field resulting in a temporary rearrangement of the cell membrane. As a result, the cells become permeable and may take up solutes from their surrounding environment, including nucleic acids, proteins, carbohydrates, and small molecules. While much work has been done to determine how cells become permeabilized during the process of electroporation, the membrane changes that occur are still largely hypothetical (Chang et al. 1992).

The Gene Pulser Xcell System electroporation instrument is capable of delivering both exponential decay and square-wave pulses (Figure 4.1). The system consists of a pulse generator system (the main unit with either or both the CE module and PC module), a shocking chamber, and a cuvette with incorporated electrodes (see Section 2). Activating the pulse button on the Gene Pulser Xcell System charges the capacitors in the unit and, if attached, in the CE module, to a high voltage; the instrument then discharges the current in the capacitor into the sample in the cuvette. Discharging the charged capacitor generates either the exponential-decay or the square-wave pulse.

There are two instrument parameters that describe the changes that the cells experience upon electroporation. The first of these, the electric field strength, E , measured in volt/cm, describes the electrical environment in the electroporation chamber. Standard electrodes used in electroporation consist of two parallel plates separated by a distance, d (cm); therefore,

$$E = V / d,$$

where V is the applied voltage and d is the distance between the electrodes. In practical terms, the field strength is manipulated by altering the voltage of the instrument or by changing the distance between the electrodes. Because the electric conductance of the cell cytoplasm is much higher than that of the cell membrane, placing the cell in an electric field creates a voltage potential across the cell membrane. As the field strength increases, the transmembrane voltage experienced by the cell increases as does the likelihood that a pore will form in the membrane due to breakdown of the lipid bilayer, allowing molecules to enter the cell from the outside (Hui 1995; Neumann et al. 2000).

The second parameter that affects the cell is the length of time that it is exposed to the electric field. For exponential decay pulses, this is controlled by the capacitance of the instrument and the resistance within the circuit. For square-wave pulses, the pulse length is controlled directly by setting the time that the cells are exposed to the electric field. These are discussed for each pulse type below.

4.1 Exponential Decay Pulses

The exponential decay circuit of the Gene Pulser Xcell System generates an electrical pulse by discharging a capacitor. When a capacitor is discharged into the sample, the voltage across the electrodes rises rapidly to the peak voltage, then declines over time, t , with an exponential decay waveform (Figure 4.1A) according to the following equation:

$$V_t = V_0 [e^{-(t/RC)}],$$

where V_0 is the initial voltage in the capacitor, V_t is the voltage at time = t (ms) after the pulse, e is the base of the natural logarithm, R is the resistance of the circuit (expressed in ohms), and C is the capacitance (expressed in microfarads). The time required for the initial voltage to drop to V_0 / e is referred to as the time constant, τ , a convenient expression of the pulse length (expressed in milliseconds). When $t = \tau = R \times C$, the voltage has declined to $1/e$ (~37%) of the initial value, V_0 ($V_\tau = V_0 / e$).

By changing the capacitor of the instrument or by changing the resistance of the circuit, the time constant may be readily changed. When high-resistance medium is used (e.g., low ionic-strength medium used for most bacteria and yeast), the resistance of the circuit may be controlled using the PC module which places a resistor in parallel with the sample. For resistors connected in parallel, the total resistance of the circuit is given by the equation

$$R_T = (R_{\text{sample}} \times R_{\text{PC}}) / (R_{\text{sample}} + R_{\text{PC}}).$$

When the sample resistance is much greater than the resistor in the PC module ($R_{\text{sample}} \gg R_{\text{PC}}$), the latter is the primary determinant of the resistance of the circuit and $R_T \sim R_{\text{PC}}$. Therefore, the PC module reduces the resistance of the circuit thereby reducing the time constant of the circuit.

When low-resistance medium is used (e.g., high ionic-strength medium, such as phosphate buffered saline [PBS], or growth medium used for most mammalian cells), the time constant is most easily manipulated by selecting the proper capacitor for the circuit using the CE module. Additionally, changing the volume of low-resistance medium in the cuvette will alter the resistance of the circuit (resistance is inversely proportional to volume).

4.2 Square-Wave Pulses

Truncating the pulse from a capacitor after discharging it into the sample generates square-wave pulses. The ideal square-wave pulse has the same voltage at the end as at the beginning of the pulse (Figure 4.1B). However, using a charged capacitor to produce this waveform (as is done in all commercially available electroporation instruments), the voltage at the end of the pulse, V_t , is always less than the voltage at the beginning of the pulse, V_0 . This is because when the switch is closed across a charged capacitor, maximum current instantaneously flows through the circuit and gradually falls to zero. To produce a square-wave, the pulse is terminated at some time, t , following discharge of the capacitor. This time (t) is termed the pulse length. The longer the pulse length, the greater is the difference in voltage between the beginning and the end of the pulse. This voltage decay may be determined from the following equation:

$$\ln (V_0 / V_t) = t / (R \times C).$$

The decrease in voltage that occurs with a square-wave pulse is inversely related to both the capacitance of the instrument and the resistance of the sample. The fractional decrease in voltage at the end of the pulse as a function of the initial voltage, V_0 , is termed droop and is given by the following equation:

$$\text{Droop} = (V_0 - V_t) / V_0.$$

Combining the two equations: $\ln (1 / [1 - \text{Droop}]) = t / (R \times C)$.

In order for the pulse to most closely approximate a true square-wave, droop must be minimized (i.e., $V_t = V_0$ and $V_0 - V_t = 0$). Experimentally, this is achieved by choosing the highest values for R and C. For any given sample, R may be considered a constant. The Gene Pulser Xcell System uses a 50- μF capacitor for the high-voltage circuit and a 3,275- μF capacitor for the low-voltage circuit. For each of these circuits, C may also be considered a constant. Therefore, for the same sample, as pulse length increases, droop also increases. However, increasing sample resistance reduces the droop at any given pulse length. Increasing the sample resistance may be accomplished by (1) reducing the temperature of the sample; (2) reducing the ionic concentration of the solution; and (3) reducing the volume of liquid in the electroporation cuvette in the case of low-resistance media. Never use the PC module when performing square-wave pulsing because attaching a resistor from the PC module in parallel with the sample will result in increasing the droop of the pulse. Table 4.1 gives the pulse lengths corresponding to a given droop as a function of resistance in the high-voltage and low-voltage ranges. For example, pulsing into a 200- Ω load, the pulse length will be 0.510 ms with a 5% droop in the high-voltage range and 33.4 ms with a 5% droop in the low-voltage range.

Table 4.1. Droop associated with pulse length at various sample resistances for the high-voltage and low-voltage ranges for the Gene Pulser Xcell System.

Sample Resistance, Ω	High-Voltage Circuit, Droop %			Low-Voltage Circuit, Droop %		
	5	10	20	5	10	20
	Pulse Length, ms			Pulse Length, ms		
20	0.051	0.109	0.223	3.34	7.14	14.6
200	0.510	1.09	2.23	33.4	71.4	146
1,000	2.55	5.45	11.2	167	357	730
3,500	8.93	19.1	39.0	585	1,249	2,556

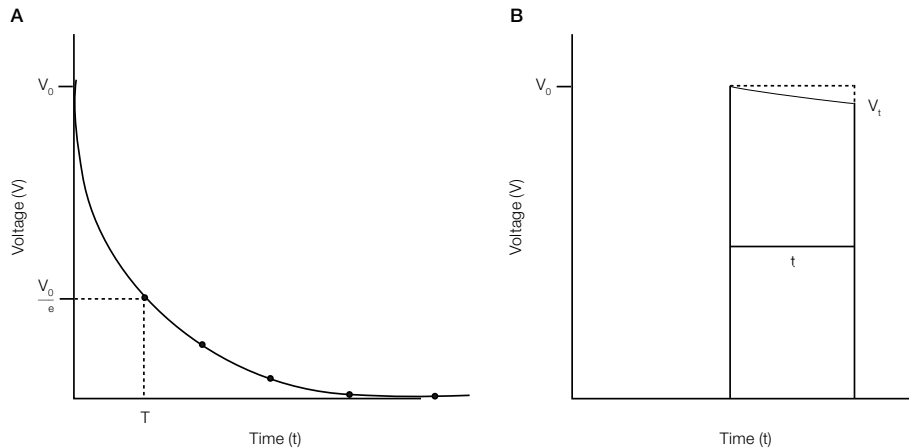

Fig. 4.1. A, exponential decay pulse from a capacitance discharge system. When a capacitor, charged to an initial voltage V_0 , is discharged into cells, the voltage applied to the cells decreases over time in an exponential curve such that the voltage "V" at any given time "t" is given by $V = V_0 e^{-t/(RC)}$. In the special case where $t = RC$ then V_0/e . The value CR is known as the time constant of the voltage decay. The shorter the time constant, the faster the decay. **B, square-wave pulse from a capacitance discharge system.** The pulse length is the time the cells are subjected to the discharge. During the pulse, the voltage again decreases in an exponential decay so that at the end of the pulse the voltage is lower than at the beginning. We call this drop in voltage the pulse droop and measure it as a percentage of the initial voltage.

Section 5

Factors Affecting Electroporation: Optimizing Electroporation

The electrical conditions for the electroporation of cells have been verified through years of research (see Shigekawa and Dower 1988; Change et al. 1992; and Nickoloff 1995a,b for overviews as well as for protocols on electroporation of numerous species). For suggestions on optimizing electroporation

parameters, see the following references: Calvin and Hanawalt 1988; Dower et al. 1988 (for bacterial cells); Shillito et al. 1985; Fromm et al. 1987; Dekeyser et al. 1990; Joersbo and Brunstedt 1991 (for plant cells); Chu et al. 1987; Knutson and Yee 1987; Andreason and Evans 1989; Anderson et al. 1989; and Heiser 1999 (for mammalian cells). For microorganisms, optimum electrotransformation occurs using exponential decay pulses under electrical conditions similar to those used for *Escherichia coli* and *Saccharomyces cerevisiae*, two species that are most commonly used in research today — low capacitance (short pulse duration) at high voltage. For *E. coli*, conditions that result in a field strength of ~18 kV/cm and a time constant of ~5 ms are optimal. For many bacterial species, including *Salmonella*, *Borrelia*, *Lactococcus*, and *Enterococcus*, the conditions for electroporation are generally identical to those used for *E. coli*. For many other bacterial species, altering the field strength will often result in higher electrotransformation. For *S. cerevisiae*, conditions that result in a field strength of ~7.5 kV/cm and a time constant of ~5 ms are near optimal. Similar optimal conditions are also found with other species of yeast.

Successful electroporation of plant protoplasts has been obtained using exponential decay pulses at both low-capacitance and high-voltage settings or high-capacitance (long pulse duration) and low-voltage settings. Typical conditions are time constants of 10–100 μ s and field strengths of 2.5–5 kV/cm or time constants of 2–5 ms and a field strength of about 500 V/cm.

For mammalian cells, optimum electrotransformation conditions have been reported using both exponential-decay and square-wave pulses. Typical conditions for both types of pulses employ pulse lengths or time constants of 10–40 ms and field strengths of 400–900 V/cm. Generally, there is an inverse relationship between field strength and pulse length or time constant such that, over a limited range, one variable may be increased and the other decreased in order to maintain the optimum electroporation conditions. Additionally, as cell size increases, the field strength at which optimum electrotransformation occurs generally decreases. Other conditions that are important for maximizing electroporation efficiency are discussed in the following sections.

5.1 Cell Growth

The optimal portion of the growth phase to harvest cells is generally dependent on the cell type. When preparing competent cells of a new species, it is generally best to start with conditions employed for use within the same genus. Suggestions for factors to consider and general methods for producing electrocompetent cells are discussed in the articles by Dower et al. 1992 and Trevors et al. 1992. For most bacterial species, the highest transformation efficiencies are obtained when cells are harvested in early- to mid-log growth. With *E. coli*, as the cells reach stationary phase, the transformation efficiency declines precipitously (Dower 1990). In contrast, most yeast species are generally harvested in mid- to late-log growth. For *S. cerevisiae*, the transformation efficiency increases as much as 60-fold from early- to late-log cultures (Becker and Guarente 1991). For mammalian cells, the highest expression following electroporation is obtained when cells are in mid-log phase growth (Anderson et al. 1991).

5.2 DNA

While the majority of electroporation applications involve delivery of plasmid DNA to cells, nearly any type of molecule can be introduced into cells by electroporation, including RNA, proteins, carbohydrates, and small molecules, such as nucleoside triphosphates and fluorescent dyes. With few exceptions, when delivering autonomously replicating plasmids, the highest transformation efficiencies are obtained when electroporating supercoiled plasmid; this is the case for microorganisms, plant, and animal cells. However, integration of electroporated plasmid into the host genome is usually most efficient using linearized plasmid, such as when isolating stable transformants of mammalian cells (Barsoum 1995) or studying homologous recombination in *Candida* (Thompson et al. 1998), *Pichia* (Cregg and Russell 1998), and *Tetrahymena* (Gaertig and Gorovsky 1995). Addition of carrier, such as salmon sperm DNA or plasmid, has also been shown to increase gene expression in some cell lines (Chu et al. 1987; Showe et al. 1990).

Although transformation of most cell types has been accomplished using plasmid DNA isolated by a variety of methods, the plasmid purity has an effect on transformation efficiency. Significantly lower transformation efficiencies are generated with unpurified miniprep plasmid DNA than with plasmid DNA that has been purified. Plasmid produced using the Bio-Rad Aurum matrix is as efficient as CsCl-purified plasmid for transformation of both microorganisms and mammalian cells. However, as long as plasmids are prepared in the same manner, changes in expression levels are due to differences in transcription or translation of the gene of interest.

Finally, when electroporating ligation mixtures into *E. coli*, components in the reactions have been shown to interfere with transformation (Dower 1990). Heating the ligation mixture (65°C for 15 min) followed by dilution with water (Willson and Gough 1988), dialysis (Heery and Dunican 1989; Jacobs et al. 1990), or ethanol precipitation (Böttger 1988; Zabarovsky and Winberg 1990) significantly increases the transformation efficiency of the DNA.

5.3 Electroporation Media

Many types of microorganisms are most efficiently electroporated in high-resistance media (resistance >3,000 Ω). For this reason, when preparing electrocompetent cells, it is important to wash cells thoroughly to remove all traces of ions present in the growth media. Failure to thoroughly remove the growth medium from the cells may result in the sample arcing during electroporation at high field strengths. Cells should be washed at least three times with water or with nonionic solutions, such as glucose, glycerol, sucrose, or sorbitol. For many microorganisms, 10–15% glycerol is a convenient electroporation medium, since it is recommended as a cryoprotectant for storage of cell cultures.

In some bacterial species, including low (~1 mM) amounts of $MgCl_2$ in the electrophoresis buffer increases the transformation efficiency. At least in some bacteria, Mg^{2+} ions probably maintain the structural integrity of the cell membrane. For example, *Pseudomonas aeruginosa* is very sensitive to divalent cation chelators; incubation of cells in the presence of EDTA destabilizes the outer membrane of the cells (Haque and Russell 1974). In the absence of Mg^{2+} ions, the membrane may not be able to reform following electroporation.

Figures 5.1A and 5.1B show the effect of concentration of several biologically important ionic solutions on sample resistance. **Note:** (1) the volume of liquid in the cuvette has a significant effect on sample resistance — for ionic solutions, sample resistance is inversely proportional to the volume of solution in the cuvette; (2) the resistance of a solution containing divalent ions is lower than a solution containing the same concentration of monovalent ions; and (3) the resistance of a buffered solution is affected by its pH.

The addition of even small concentrations of ionic compounds significantly reduces the resistance of high-resistance samples and may cause arcing. Residual salt from ethanol precipitation of DNA should be removed by washing the DNA pellet prior to dissolving it in either water or Tris-EDTA (TE). Table 5.1 shows that adding a solution of plasmid in 10 mM Tris, pH 8.0, 1 mM EDTA to water does reduce the sample resistance. This should be considered when electroporating bacterial samples in high-resistance media. DNA may be used directly from enzyme reactions for transformation, but the final salt concentration in the electroporation sample should be kept below ~5 meq for high-voltage operation.

5.4 Temperature

The temperature at which cells are maintained during electroporation would be expected to have a role in the efficiency of the electroporation process for several reasons. First, since passing an electric pulse through the cells results in heating, keeping the cells at a low temperature during the pulse might reduce the heating and therefore increase the cell viability. Second, since electroporation involves the transient formation of pores in the cell membrane, keeping cells at a low temperature after the pulse might allow the pores to remain open longer giving the DNA in the medium more time to enter the cells. Alternatively,

a higher temperature may speed pore closure and decrease cell viability. Third, changing the temperature of a solution changes its conductivity. The conductivity of the medium increases with increasing temperature, resulting in a decrease in the medium resistance and a decrease in the time constant, τ . Finally, diffusion rate is highly dependent on temperature, and keeping cells at a low temperature would be expected to reduce the diffusion of molecules across the cell membrane. In practice, the most efficient temperature at which to electroporate cells must be determined empirically. Most bacterial cells are most electrocompetent when maintained at $<4^{\circ}\text{C}$ from the time of harvest until pulsing. The transformation efficiency of *E. coli* decreases by ~ 100 -fold if pulsed at 20°C (Shigekawa and Dower 1988); however, electrocompetent *S. aureus* should be incubated at room temperature prior to electroporation (Lee 1995). For most mammalian cells, electroporation is most efficient when cells are maintained at room temperature both before and after the pulse (Chu et al. 1987), although some cell types are more efficiently transformed at low temperature (Potter et al. 1984).

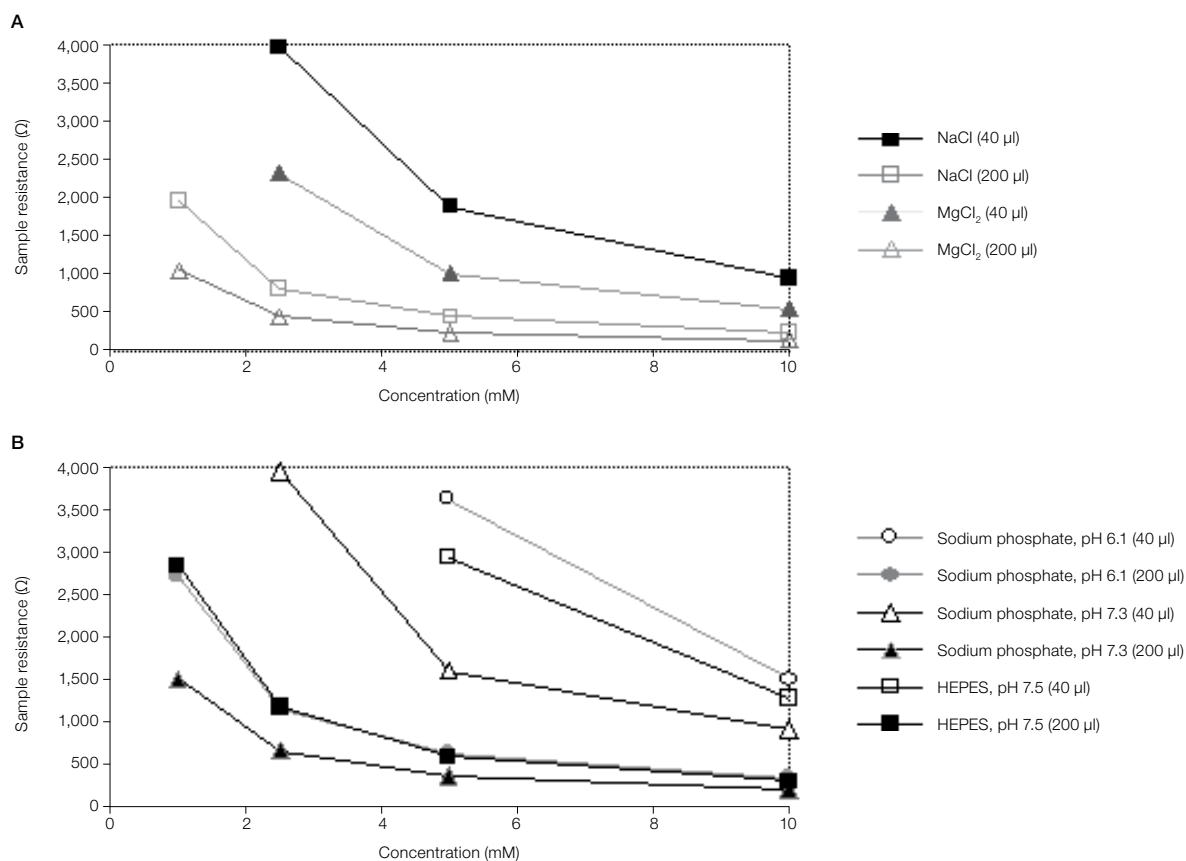

Fig. 5.1. Resistance of solutions A, NaCl and MgCl₂ and B, buffers of sodium phosphate at pH 6.1 and 7.3 and HEPES at pH 7.5. Resistance was measured in 0.2-cm cuvettes containing either 40 or 200 μl of solution at room temperature.

Table 5.1. Resistance of water in 0.2-cm cuvettes to which TE has been added.*

Sample	$R_{\text{sample}}, \Omega$ (40 μl)	$R_{\text{sample}}, \Omega$ (200 μl)
Water	>600,000	>600,000
Water + 1 μl TE	>600,000	35,000
Water + 5 μl TE	11,200	8,700
Water + 10 μl TE	4,850	4,700

*Sample resistance in 0.2-cm cuvettes containing either 40 or 200 μl of water and the indicated volume of TE (10 mM Tris, pH 8.0, 1 mM EDTA) measured at 1,000 V.

Section 6

Electroporation of Bacterial Cells

For most bacterial species, electroporation provides a rapid and simple method for transforming cells. Particularly for gram-negative bacteria, but also for some gram-positive species, this method provides higher transformation efficiencies than conjugation or chemical methods.

6.1 *Escherichia coli*

6.1.1 Preparation of Electrocompetent Cells

See Ausubel et al. 1987 and Miller and Nickoloff 1995 for additional information.

The Gene Pulser Xcell System conditions: C = 25 μ F; PC = 200 Ω ; V = 1.8 kV (in 0.1-cm cuvettes);
C = 25 μ F; PC = 200 Ω ; V = 2.5 kV, or
C = 25 μ F; PC = 200 Ω ; V = 3.0 kV (in 0.2-cm cuvettes).

This procedure requires a Gene Pulser Xcell main unit and PC module.

1. Inoculate 5 ml of a fresh overnight *E. coli* culture into 500 ml of LB broth in a 2.8-L Fernbach flask.
2. Grow the cells at 37°C shaking at 300 rpm to an OD 600 of approximately 0.5–0.7. The best results are obtained with cells that are harvested at early- to mid-log phase; the appropriate cell density depends on the strain and growth conditions but should be about 4–5 $\times 10^7$ cells/ml.
3. Chill the cells on ice for ~20 minutes. For all subsequent steps, keep the cells as close to 0°C as possible (in an ice-water bath) and chill all containers in ice before adding cells. Transfer the cells to a sterile, cold 500-ml centrifuge bottle and centrifuge at 4,000 \times g for 15 min at 4°C.
4. Carefully pour off and discard the supernatant. It is better to sacrifice yield by pouring off a few cells than to leave any supernatant behind.
5. Gently resuspend the pellet in 500 ml of ice-cold 10% glycerol. Centrifuge at 4,000 \times g for 15 min at 4°C; carefully pour off and discard the supernatant.
6. Resuspend the pellet in 250 ml of ice-cold 10% glycerol. Centrifuge at 4,000 \times g for 15 min at 4°C; carefully pour off and discard the supernatant.
7. Resuspend the pellet in ~20 ml of ice-cold 10% glycerol. Transfer to a 30-ml sterile Oakridge tube. Centrifuge at 4,000 \times g for 15 min at 4°C; carefully pour off and discard the supernatant.
8. Resuspend the cell pellet in a final volume of 1–2 ml of ice-cold 10% glycerol. The cell concentration should be about 1–3 $\times 10^{10}$ cells/ml.
9. This suspension may be frozen in aliquots on dry ice and stored at –70°C. The cells are stable for at least 6 months under these conditions.

6.1.2 Electroporation

1. Thaw the cells on ice. For each sample to be electroporated, place a 1.5-ml microfuge tube on ice, place either a 0.1-cm or 0.2-cm electroporation cuvette on ice, and place a 17 x 100-mm tube with 1 ml of SOC at room temperature.
2. To a cold, 1.5-ml polypropylene microfuge tube, add 20 μ l of cell suspension if electroporating in 0.1-cm cuvettes, or 20–40 μ l of cell suspension if electroporating in 0.2-cm cuvettes. Add 1–2 μ l of DNA (DNA should be in a low ionic strength buffer, such as water or TE). Mix well and incubate on ice for ~1 minute. (**Note:** It is best to mix the plasmids and cells in a microfuge tube since the narrow gap of the cuvettes prevents uniform mixing.)
3. From the Home screen on the Gene Pulser Xcell System open the Preset Protocols screen, then the Bacterial Protocol screen (press 4, then Enter twice). When using the 0.1-cm cuvettes, press Enter to open *E. coli*, 1-mm cuvette Protocol Detail screen. When using the 0.2-cm cuvettes, press 2 then Enter, or 3 then Enter, to select the Protocol Detail screens for *E. coli* to pulse at 2.5 or 3.0 kV, respectively. See Section 3.4 for operating instructions.
4. Transfer the mixture of cells and DNA to a cold electroporation cuvette and tap the suspension to the bottom. Place the cuvette in the ShockPod. Push the chamber lid down to close.
5. Pulse once.
6. Remove the cuvette from the chamber and immediately add 1 ml of SOC medium to the cuvette. Quickly but gently resuspend the cells with a Pasteur pipette. (The period between applying the pulse and transferring the cells to outgrowth medium is crucial for recovering *E. coli* transformants [Dower et al. 1988]. Delaying this transfer by even 1 minute causes a threefold drop in transformation. This decline continues to a 20-fold drop by 10 minutes.)
7. Transfer the cell suspension to a 17 x 100-mm polypropylene tube and incubate at 37°C for 1 hr, shaking at 225 rpm.
8. Check and record the pulse parameters. The time constant should be close to 5 milliseconds. The field strength can be calculated as actual kilovolts (kV) / cuvette gap (cm).
9. Plate on LB plates with antibiotic.

6.1.3 Solutions and Reagents

1. LB broth: 10 g tryptone peptone, 5 g yeast extract, 5 g NaCl; dissolve in 1.0 L of water. Autoclave.
2. LB agar plates with selective antibiotic: prepare LB broth as above, adding 15 g of agar per liter. Autoclave. Cool to 55–60°C and add antibiotic. Pour 12–15 ml per 100-mm plate.
3. 10% (v/v) glycerol: 12.6 g glycerol (density = 1.26 g/ml) in 90 ml of water. Autoclave or filter sterilize.
4. TE: 10 mM Tris, pH 8.0, 1 mM EDTA.
5. SOB: 2.0 g tryptone peptone, 0.5 g yeast extract, 0.2 ml 5 M NaCl, 0.25 ml 1 M KCl; dissolve in 90 ml water. Adjust pH to 7.0. Bring volume to 100 ml. Autoclave. Add 1.0 ml sterile 1 M MgCl₂ and 1.0 ml sterile 1 M MgSO₄.
6. SOC: to 100 ml SOB, add 2.0 ml sterile 1 M glucose (sterilize by filtration).

6.2 *Staphylococcus aureus*

6.2.1 Preparation of Electrocompetent Cells

See Lee 1995 for additional information.

Using this method, we have obtained transformation efficiencies of $>1 \times 10^6$ transformants/ μg electroporating *S. aureus* RN4220 with pLI50.

The Gene Pulser Xcell System conditions: C = 25 μF ; PC = 100 Ω ; V = 2.9 kV.

This procedure requires a Gene Pulser Xcell main unit and PC module.

1. Inoculate a colony of *S. aureus* from a TSA plate into 3 ml of B2 broth in a 17 x 100-mm tube.
2. Incubate at 37°C overnight, shaking at 250 rpm.
3. Inoculate 1.5 ml of the overnight culture into 150 ml of B2 broth in a 1-L flask. Incubate at 37°C, shaking at 250 rpm, to $3\text{--}5 \times 10^8$ cells/ml (OD 600 ~0.8–0.85). The doubling time of *S. aureus* is about 30 minutes at 37°C; growth will take about 4 hours.
4. Chill the cells in an ice-water bath for 15 min to stop growth. Decant the cells into a sterile 500-ml centrifuge bottle. Harvest the cells by centrifugation at 12,000 x g for 15 min at 4°C.
5. Carefully pipette off the supernatant keeping the cell pellet on ice.
6. Resuspend the cell pellet in 500 ml of sterile, ice-cold water. Pellet the cells by centrifugation at 12,000 x g for 15 min at 4°C; carefully remove the supernatant. Wash the cells two more times in 500 ml of sterile, ice-cold water.
7. Resuspend the cell pellet in 25 ml of sterile, ice-cold 10% glycerol. Transfer to a 30-ml sterile Oakridge tube. Pellet the cells by centrifugation at 12,000 x g for 15 min at 4°C; carefully remove the supernatant.
8. Resuspend the cells in 20 ml of 10% glycerol. Incubate at 20°C for 15 min. Pellet the cells by centrifugation at 12,000 x g for 15 min at 4°C; carefully remove the supernatant.
9. Resuspend the cell pellet in 2 ml of 10% glycerol; the final cell concentration should be $\sim 1 \times 10^{10}$ cells/ml.
10. Dispense 250- μl aliquots of the electrocompetent cells into sterile 1.5-ml microfuge tubes; freeze the cells in an isopropanol-dry ice bath, then store at -70°C . The cells are stable for several months under these conditions.

6.2.2 Electroporation

1. Pipette the DNA samples (5 ng–2 μg in no more than 3 μl) to be electroporated into sterile 1.5-ml microfuge tubes.
2. Thaw the competent cells at room temperature for several minutes. Add 50 μl of cells to each DNA sample; gently pipette up and down to mix. Incubate the samples at room temperature for 30 min.
3. For each sample to be electroporated, add 1 ml of SMMP medium containing a subinhibitory concentration of antibiotic to a 17 x 100-mm tube at room temperature and place a 0.2-cm cuvette at room temperature.

4. From the Home screen on the Gene Pulser Xcell System open the Preset Protocols screen, then the Bacterial Protocol screen (press 4, then Enter twice). To select the Protocol Detail screen for *S. aureus*, press 6 or the Down Arrow key to highlight *S. aureus*, then press Enter. See Section 3.4 for operating instructions.
5. Transfer the mixture of cells and DNA to a 0.2-cm electroporation cuvette at room temperature and tap the suspension to the bottom. Place the cuvette in the ShockPod. Push the chamber lid down to close.
6. Pulse once.
7. Remove the cuvette from the chamber and immediately add 1 ml of SMMP medium containing a subinhibitory concentration of antibiotic; gently transfer the cells to a sterile 17 x 100-mm tube using a Pasteur pipette. Incubate for 1 hr at 37°C, shaking at 250 rpm.
8. Check and record the pulse parameters. The time constant should be close to 2.5 milliseconds. The voltage should be approximately 2.9 kV.
9. Plate aliquots of the electroporated cells on trypticase soy agar containing selective antibiotic. Incubate plates for 36–48 hr at 37°C.

6.2.3 Solutions and Reagents

1. Trypticase soy agar (TSA): dissolve 40 g trypticase soy agar (Becton Dickinson, Sparks, MD) in 1.0 L of water. Autoclave.
2. B2 medium: 10 g casein hydrolysate (casamino acids), 25 g yeast extract, 5 g glucose, 25 g NaCl, 1 g K₂HPO₄; dissolve in 900 ml of water and adjust pH to 7.5; bring volume to 1.0 L. Autoclave.
3. 0.2 M sodium hydrogen maleate: either 11.6 g maleic anhydride and 4 g NaOH dissolved in 500 ml of water, or 13.8 g maleic acid, 4 g NaOH dissolved in 500 ml water. Autoclave.
4. 2x SMM: 25 ml of 0.2 M sodium hydrogen maleate, 40 ml of 0.1 N NaOH; adjust the pH to 6.5. Add 5 ml of 1 M MgCl₂, 42.7 g sucrose; dissolve and bring volume to 125 ml. Filter sterilize.
5. 4x Penassay broth: 17.5 g antibiotic medium 3 (Becton Dickinson) dissolved in 250 ml of water. Autoclave.
6. SMMP: 55 ml of 2x SMM, 40 ml of 4x Penassay broth, 5 ml of 10% (w/v) bovine albumin; adjust pH to 7.0; filter sterilize. For selection of antibiotic-resistant transformants, add a subinhibitory concentration of antibiotic.
7. 10% (v/v) glycerol: 12.6 g glycerol (density = 1.26 g/ml) in 90 ml of water. Autoclave or filter sterilize.

6.3 *Agrobacterium tumefaciens*

6.3.1 Preparation of Electrocompetent Cells

See Lin 1995 for additional information.

The Gene Pulser Xcell System conditions: C = 25 µF; PC = 200 Ω; V = 2.4 kV.

This procedure requires a Gene Pulser Xcell main unit and PC module.

1. Inoculate an aliquot from log phase culture of *A. tumefaciens* into 1.5 L of YM broth in a 2.8-L Fernbach flask.

2. Incubate at 30°C overnight, shaking at 300 rpm to a density of 5–10 x 10⁷ cells/ml (OD 550 ~ 1.0).
3. Decant the cells into sterile 500-ml centrifuge bottles and pellet the cells by centrifugation at 3,000 x g for 10 min at 4°C.
4. Carefully pour off and discard the supernatant; place the centrifuge bottles with the cell pellets on ice.
5. Add ~50 ml of sterile, ice-cold 10% glycerol to each of the bottles and vortex to resuspend the cell pellets; bring the volume in each of the centrifuge bottles to 500 ml with sterile, ice-cold 10% glycerol. Pellet the cells by centrifugation at 3,000 x g for 10 min at 4°C; pour off and discard the supernatant.
6. Combine the cell pellets and wash the cells in one bottle as in step 5.
7. Resuspend the cell pellets in 25 ml of sterile, ice-cold 10% glycerol and transfer to a chilled 30-ml Oakridge tube. Pellet the cells by centrifugation at 3,000 x g for 5 min at 4°C; pour off and discard the supernatant.
8. Resuspend the cell pellet in 0.5 ml of sterile, ice-cold 10% glycerol; the final cell volume should be ~1.5 ml and the cell concentration should be ~5 x 10¹⁰ cells/ml. The cells may be used immediately or frozen. To freeze, dispense 200-µl aliquots of the electrocompetent cells in sterile 1.5-ml microfuge tubes; freeze the cells in an isopropanol-dry ice bath, then store at –70°C. The cells are stable for about 6 months under these conditions.

6.3.2 Electroporation

1. Pipette the DNA samples (up to 100 ng in no more than 5 µl of TE) to be electroporated into sterile 1.5-ml microfuge tubes. Place tubes on ice.
2. Thaw the electrocompetent *A. tumefaciens* cells on ice. To each DNA sample to be electroporated, add 20 µl of electrocompetent cells; gently tap the tubes to mix.
3. To each DNA sample to be electroporated, add 1 ml of YM broth to a 17 x 100-mm tube at room temperature and place a 0.1-cm electroporation cuvette on ice.
4. From the Home screen on the Gene Pulser Xcell System open the Preset Protocols screen, then the Bacterial Protocol screen (press 4, then Enter twice). To select the Protocol Detail screen for *A. tumefaciens*, press 4 or the Down Arrow key to highlight *A. tumefaciens*, then press Enter. See Section 3.4 for operating instructions.
5. Transfer the DNA-cell samples to the electroporation cuvettes and tap the suspension to the bottom. Place the cuvette in the ShockPod. Push the chamber lid down to close. Pulse once.
6. Remove the cuvette from the chamber and immediately use the 1 ml of YM broth in the 17 x 100-mm tube to transfer the cells from the cuvette to the tube.
7. Check and record the pulse parameters. The time constant should be about 5 milliseconds. The voltage should be about 2.4 kV.
8. Incubate the cells for 3 hr at 30°C, shaking at 250 rpm. Plate aliquots of the electroporated cells on YM agar plates containing the appropriate selective medium. Incubate plates for 48 hr at 30°C.

6.3.3 Solutions and Reagents

1. YM broth: 0.4 g yeast extract, 10 g mannitol, 0.1 g NaCl, 0.1 g MgSO₄, 0.5 g K₂HPO₄·3H₂O, dissolve in 1.0 L of water and adjust to pH 7.0. Autoclave. For YM plates, add 15 g agar/1 L of YM broth.
2. 10% (v/v) glycerol: 252 g glycerol (density = 1.26 g/ml) in 1,800 ml water. Autoclave or filter sterilize.

6.4 *Bacillus cereus*

6.4.1 Preparation of Electrocompetent Cells

Slight modification of the method of Silo-Suh et al. 1994.

Using this method, we have obtained transformation efficiencies of 2×10^6 transformants/ μg electroporating *B. cereus* UW85 with pAD123.

The Gene Pulser Xcell System conditions: C = 50 μF ; PC = 200 Ω ; V = 1.0 kV.

This procedure requires a Gene Pulser Xcell main unit and PC module.

1. Inoculate a colony of *B. cereus* into 10 ml of LB in a 125-ml flask; incubate overnight at 28°C shaking at 300 rpm.
2. Inoculate 2 ml of the overnight culture into 500 ml of BHI in a 2.8-L Fernbach flask; incubate at 28°C shaking at 300 rpm.
3. Monitor the culture until OD 600 = 0.3 (cell density is $\sim 1 \times 10^7$ cells/ml).
4. Chill the culture on ice for 10 min.
5. Transfer the cells into two chilled, sterile 250-ml centrifuge bottles.
6. Pellet the cells by centrifugation at 4°C for 10 min at 10,000 x g in a chilled rotor.
7. Discard the supernatant. Resuspend each pellet in 50 ml of sterile, ice-cold EP buffer. Pellet the cells as above.
8. Discard the supernatant. Resuspend each pellet in 15 ml of sterile, ice-cold EP buffer. Transfer to a chilled 30-ml Oakridge tube.
9. Pellet the cells by centrifugation at 4°C for 10 min at 10,000 x g in a chilled rotor.
10. Discard the supernatant. Resuspend the cell pellet in 0.5 ml of EP buffer. Keep the cells on ice and use as soon as possible for electroporation. Cells cannot be frozen and used for electroporation.

6.4.2 Electroporation

1. For each sample to be electroporated, pipette the DNA (0.05–1 μg in up to 10 μl of either water or TE) into a sterile 1.5-ml microfuge tube. Place tubes on ice. Add 100 μl electrocompetent cells to each plasmid sample; mix, and incubate on ice for 5–10 min.
2. Transfer 100 μl of plasmid/cell suspension to chilled 0.2-cm cuvettes on ice; tap the solution to the bottom of the cuvette.
3. For each DNA sample to be electroporated, prepare a 17 x 100-mm tube containing 2.0 ml of LB at room temperature.

4. From the Home screen on the Gene Pulser Xcell System open the Preset Protocols screen, then the Bacterial Protocol screen (press 4, then Enter twice). To select *B. cereus*, press 7 or the Down Arrow to highlight *B. cereus*, then press Enter to open the *B. cereus* Protocol Detail screen. See Section 3.4 for operating instructions.
5. Transfer the DNA-cell samples to the electroporation cuvettes and tap the suspension to the bottom. Place the cuvette in the ShockPod. Push the chamber lid down to close. Pulse once.
6. Remove the cuvette from the chamber and immediately use a portion of the LB broth in the 17 x 100-mm tube to transfer the cells from the cuvette to the tube.
7. Check and record the pulse parameters. The time constant should be about 8.6 milliseconds and the voltage about 1.0 kV. The field strength can be calculated as actual kilovolts (kV) / cuvette gap (cm).
8. Incubate the cells for 1–1.5 hr at 37°C, shaking at 250 rpm.
9. Plate aliquots of the electroporated cells on LB agar plates containing the appropriate selective medium. Incubate plates overnight at 28°C.

6.4.3 Solutions and Reagents

1. EP buffer (0.5 mM K_2HPO_4 - KH_2PO_4 , 0.5 mM $MgCl_2$, 272 mM sucrose): 54.4 ml 1 M sucrose, 100 μ l 1 M $MgCl_2$, 190 μ l 0.1 M KH_2PO_4 , 810 μ l 0.1 M K_2HPO_4 . Bring volume to 200 ml with Milli-Q water (the pH should be ~7.4). Filter sterilize. Store at 4°C.
2. Brain Heart Infusion (BHI): dissolve 37 g BHI in 1.0 L of water; autoclave.
3. LB Broth: 10 g tryptone peptone, 5 g yeast extract, 5 g NaCl; dissolve in 1.0 L of water. Autoclave.

6.5 *Pseudomonas aeruginosa*

6.5.1 Preparation of Electrocompetent Cells

From Dennis and Sokol 1995 and Smith and Iglewski 1989.

Using this method, electroporating *P. aeruginosa* PAO1 with pUCP19, we have obtained transformation efficiencies $>1 \times 10^7$ transformants/ μ g.

The Gene Pulser Xcell System conditions: C = 25 μ F; PC = 200 Ω ; V = 2.5 kV.

This procedure requires a Gene Pulser Xcell main unit and PC module.

1. Inoculate a colony of *P. aeruginosa* into 25 ml of LB in a 125-ml flask; incubate overnight at 37°C shaking at 300 rpm.
2. Inoculate 10 ml of the overnight culture into a 2.8-L Fernbach flask with 500 ml of LB; incubate at 37°C shaking at 300 rpm.
3. Monitor the culture until OD 600 = 0.5; the cell density should be $\sim 3 \times 10^8$ cells/ml.
4. Chill the flask on ice for 10 min.
5. Transfer the cells into two chilled, sterile 250-ml centrifuge bottles.
6. Pellet the cells by centrifugation at 4°C for 10 min at 2,300 x g in a chilled rotor.

7. Discard the supernatant. Resuspend each pellet in 250 ml of sterile, ice-cold SMEB buffer. Pellet the cells as above.
8. Discard the supernatant. Resuspend each pellet in 125 ml of sterile, ice-cold SMEB buffer. Pellet the cells as above.
9. Discard the supernatant. Resuspend each pellet in 12 ml of sterile, ice-cold SMEB buffer. Transfer to a chilled 30-ml Oakridge tube.
10. Pellet the cells by centrifugation at 4°C for 10 min at 2,300 x g in a chilled rotor.
11. Discard the supernatant. Resuspend the cell pellet in 2.0 ml of SMEB buffer. Keep the cells on ice and use as soon as possible for electroporation.

6.5.2 Electroporation

1. For each sample to be electroporated, pipette 0.05–0.5 µg of plasmid into a sterile 1.5-ml microfuge tube. Place tubes on ice. Add 100 µl electrocompetent *P. aeruginosa* cells to each plasmid sample; mix and incubate on ice for 5–10 min.
2. Transfer 100 µl of plasmid/cell suspension to chilled 0.2-cm cuvettes on ice; tap the solution to the bottom of the cuvette.
3. For each DNA sample to be electroporated, prepare a 17 x 100-mm tube containing 1.0 ml of SOC at room temperature.
4. From the Home screen on the Gene Pulser Xcell System open the Preset Protocols screen, then the Bacterial Protocol screen (press 4, then Enter twice). To select *P. aeruginosa*, press 5 or the Down Arrow to highlight *P. aeruginosa*, then press Enter to open the *P. aeruginosa* Protocol Detail screen. See Section 3.4 for operating instructions.
5. Place the cuvette in the ShockPod. Push the chamber lid down to close. Pulse once.
6. Immediately after the pulse, use the 1 ml of SOC broth in the 17 x 100-mm tube to transfer the plasmid/cell suspension from the cuvette to the tube. Check and record the pulse parameters. The time constant should be about 5 milliseconds and the voltage about 2.5 kV. The field strength can be calculated as volts (kV) / cuvette gap (cm).
7. Incubate the cells for 1 hr at 37°C shaking at 250–300 rpm.
8. Plate onto LB agar plates with selective antibiotic. Incubate overnight at 37°C.

6.5.3 Solutions and Reagents

1. SMEB buffer (1 mM HEPES, pH 7.0, 1 mM MgCl₂, 300 mM sucrose): 2.0 ml 0.5 M HEPES, pH 7.0, 1.0 ml 1.0 M MgCl₂, 102.7 g sucrose. Dissolve in water and bring volume to 1,000 ml. Autoclave. Store at 4°C.
2. LB Broth: 10 g tryptone peptone, 5 g yeast extract, 5 g NaCl; dissolve in 1.0 L of water. Autoclave.
3. LB agar plates with selective antibiotic: prepare LB broth as above, adding 15 g of agar per liter. Autoclave. Cool to 55–60°C and add antibiotic. Pour 12–15 ml per 100 mm plate.

4. SOB: 2.0 g tryptone peptone, 0.5 g yeast extract, 0.2 ml 5 M NaCl, 0.25 ml 1 M KCl; dissolve in 90 ml water. Adjust pH to 7.0. Bring volume to 100 ml. Autoclave. Add 1.0 ml sterile 1 M MgCl₂ and 1.0 ml sterile 1 M MgSO₄.
5. SOC: to 100 ml SOB, add 2.0 ml sterile 1 M glucose (sterilize by filtration).

6.6 *Streptococcus pyogenes*

6.6.1 Preparation of Electrocompetent Cells

From Simon and Ferretti 1995.

Using this method, we have obtained transformation efficiencies of 1×10^5 transformants/ μg electroporating *S. pyogenes* CS101 with pDC123 (Chaffin and Rubens 1998).

The Gene Pulser Xcell System conditions: C = 25 μF ; PC = 200 Ω ; V = 2.1 kV.

This procedure requires a Gene Pulser Xcell main unit and PC module.

1. Inoculate a colony of *S. pyogenes* from a fresh plate into a 25-ml tube containing 20 ml of THY with 20 mM glycine; cap the tube tightly. Incubate overnight at 37°C without shaking.
2. Inoculate 18 ml of the overnight culture into a 500-ml flask containing 250 ml of THY medium with 20 mM glycine. Swirl gently to mix and continue incubation (about 2 hours) until the OD 600 is ~0.2 (the cell density should be about 3×10^7 cells/ml).
3. Chill the culture on ice for 10 min.
4. Transfer the cells into a chilled, sterile 500-ml centrifuge bottle.
5. Pellet the cells by centrifugation at 4°C for 10 min at 6,000 x g in a chilled rotor.
6. Pipette off and discard the supernatant. Resuspend the cell pellet in 10 ml of ice-cold sterile Elpo medium, then bring the volume to ~225 ml. Centrifuge the cells at 8,000 x g.
7. Pipette off and discard the supernatant. Resuspend the pellet in 5 ml of ice-cold sterile Elpo medium and transfer to a 30-ml Oakridge tube. Bring the volume to 30 ml, then centrifuge the cells at 12,000 x g.
8. Pipette off and discard the supernatant. Resuspend the cell pellet in about 1.5 ml of ice-cold sterile Elpo medium. Keep the cells on ice and use as soon as possible for electroporation.

6.6.2 Electroporation

1. Pipette the DNA samples to be electroporated (0.05–0.5 μg) into sterile 1.5-ml microfuge tubes. Place tubes on ice. Add 200 μl electrocompetent *S. pyogenes* cells to each plasmid sample; mix, and incubate on ice for 5–10 min.
2. Transfer 200 μl of plasmid/cell suspension to chilled 0.2-cm cuvettes on ice; tap the solution to the bottom of the cuvette.
3. For each sample to be electroporated, prepare a sterile 17 x 100-mm tube containing 1.0 ml of THY at room temperature.

4. From the Home screen on the Gene Pulser Xcell System open the Preset Protocols screen, then the Bacterial Protocol screen (press 4, then Enter twice). To select *S. pyogenes*, press 8 or the Down Arrow to highlight *S. pyogenes*, then press Enter to open the *S. pyogenes* Protocol Detail screen. See Section 3.4 for operating instructions.
5. Place the cuvette in the ShockPod. Push the chamber lid down to close. Pulse once.
6. Immediately after the pulse place the cuvette on ice for ~5 min. Check and record the pulse parameters. The time constant should be about 9.8 milliseconds and the voltage about 2.1 kV. The field strength can be calculated as kilovolts (kV) / cuvette gap (cm).
7. Add 1.0 ml of THY broth to the cuvette and transfer the plasmid/cell suspension to the 17 x 100-mm tube. Incubate the cells for 2 hr at 37°C without shaking.
8. Plate onto THY agar plates with selective antibiotic. Incubate 1–2 days at 37°C.

6.6.3 Solutions and Reagents

1. THY medium (Todd Hewitt broth with 0.2% yeast extract): 30 g Todd Hewitt broth, 2 g yeast extract; dissolve in 1.0 L of water. Autoclave.
2. THY + glycine: 500 ml THY medium, 5 ml 2 M glycine (15 g/100 ml).
3. THY agar with antibiotic: 30 g Todd Hewitt broth, 2 g yeast extract, 15 g Bacto agar; dissolve in 1.0 L of water. Autoclave; cool to 55–60°C and add antibiotic. Pour plates.
4. Elpo medium: 122 ml 20% glucose, 0.5 ml 1 M MgCl₂; bring to 500 ml with water and adjust pH to 6.5. Filter sterilize.

6.7 *Lactobacillus plantarum*

6.7.1 Preparation of Electrocompetent Cells

From Bringel and Hubert 1990. Using this method, we have obtained transformation efficiencies of 4×10^4 transformants/ μ g electroporating *L. plantarum* NCIB7220 with pGK12.

The Gene Pulser Xcell System conditions: C = 25 μ F; PC = 400 Ω ; V = 2.0 kV.

This procedure requires a Gene Pulser Xcell main unit and PC module.

1. Inoculate *L. plantarum* into 50 ml of MRS medium in a 500-ml flask; incubate overnight at 30°C shaking at 300 rpm. The cells should be in exponential growth (OD 600 < 1.5).
2. Inoculate a sample of the overnight culture into 500 ml of MRS/SG in a 2.8-L Fernback flask to an OD 600 = 0.05. Incubate at 30°C shaking at 80 rpm.
3. Monitor the culture until OD 600 = 0.3 (usually ~4 hours).
4. Transfer the cells into a sterile 500-ml centrifuge bottle at room temperature.
5. Pellet the cells by centrifugation at 18°C for 10 min at 3,000 x g.
6. Discard the supernatant. Resuspend the cell pellet in 250 ml of sterile water at room temperature. Centrifuge the cells as above but increase the speed to 4,000 x g.

7. Discard the supernatant. Repeat the water wash as above. Pellet the cells as above.
8. Discard the supernatant. Resuspend the cell pellet in a final volume of 2 ml of 30% PEG. Keep the cells on ice and use as soon as possible for electroporation.

6.7.2 Electroporation

1. For each sample to be electroporated, pipette 0.1–1.0 µg of plasmid into a sterile 1.50-ml microfuge tube (<2 µl). Place tubes on ice. Add 40 µl electrocompetent cells to each plasmid sample; mix.
2. Transfer 40 µl of plasmid/cell suspension to chilled 0.2-cm cuvettes on ice; tap the solution to the bottom of the cuvette.
3. From the Home screen on the Gene Pulser Xcell System open the Preset Protocols screen, then the Bacterial Protocol screen (press 4, then Enter twice). To select *L. plantarum*, press 9 or the Down Arrow to highlight *L. plantarum*, then press Enter to open the *L. plantarum* Protocol Detail screen. See Section 3.4 for operating instructions.
4. Place the cuvette in the ShockPod. Push the chamber lid down to close. Pulse once.
5. Immediately after the pulse place the cuvette on ice for 30 min. Add 1 ml MRS/SG to the cuvette and transfer the plasmid/cell suspension to a sterile 17 x 100-mm tube. Incubate the cells for 3–4 hr at 30°C without shaking.
6. Plate onto MRS agar plates containing antibiotic.
7. Incubate 2–3 days at 30°C.

6.7.3 Solutions and Reagents

1. 2x MRS (w/o glucose): 10 g Proteose Peptone No. 3 (Fisher Scientific, #DF0122-17-4), 10 g Beef Extract (Fisher Scientific, # DF0115-17-3), 5 g Yeast Extract (Fisher Scientific, # DF0127-17-9), 1 ml Tween 80, 11.5 ml 1 M K_2HPO_4 , 12.3 ml 3 M sodium acetate (NaAc), 1.9 g citric acid, 0.8 ml 1 M $MgSO_4$, 225 µl 1 M $MnSO_4$. Dissolve in water and bring the volume to 500 ml. Autoclave.
2. 1x MRS: 500 ml 2x MRS, 200 ml 10% glucose (filter sterilized), 300 ml sterile water.
3. 1x MRS Agar with antibiotic: to a 1-L bottle, add 7.5 g Bacto agar and 150 ml water; autoclave. Cool to 55°C. Warm 250 ml 2x MRS and 100 ml 10% glucose to 55°C; add to the agar. Add antibiotic. Pour plates.
4. MRS/SG (MRS with 0.75 M sorbitol + 1% glycine): 250 ml 2x MRS, 50 ml 20% glucose (sterilized by filtration), 150 ml sterile 2.5 M sorbitol, 33 ml sterile 2 M glycine, 17 ml sterile water.
5. 2 M glycine: 15.0 g in 100 ml water; filter sterilize.
6. 2.5 M sorbitol: 227.8 g sorbitol; dissolve in ~250 ml water then bring volume to 500 ml. Filter sterilize.
7. 30% PEG 1,000: 150 g PEG 1,000 (warm to ~50°C to melt; pour into beaker with ~200 ml water). Bring volume to 500 ml with water. Filter sterilize.

Section 7

Electroporation of Fungal Cells

7.1 *Saccharomyces cerevisiae*

7.1.1 Preparation of Electrocompetent Cells

See Becker and Guarante 1991 and Ausubel et al. 1987 for additional information. Using this procedure we have obtained $>5 \times 10^5$ transformants/ μg electroporating *S. cerevisiae* Sc948 with Yep352.

The Gene Pulser Xcell System conditions:

C = 25 μF ; PC = 200 Ω ; V = 1.5 kV (in 0.2 cm cuvettes), or
C = 25 μF ; PC = 200 Ω ; V = 2.5 kV (in 0.4 cm cuvettes).

This procedure requires a Gene Pulser Xcell main unit and PC module.

1. Inoculate 500 ml of YPD in a 2.8-L Fernbach flask with an aliquot from an overnight culture of *S. cerevisiae*. The doubling time of *S. cerevisiae* is approximately 2 hr at 30°C.
2. Incubate at 30°C overnight, shaking at 250 rpm, to a density of $\sim 1 \times 10^8$ cells/ml (OD 600 [1:10 dilution] = 0.30–0.35).
3. Chill the cells in an ice-water bath for 15 min to stop growth.
4. Decant the cells into a sterile 500-ml centrifuge bottle and pellet the cells by centrifugation at 4,000 x g for 5 min at 4°C.
5. Carefully pour off and discard the supernatant; place the centrifuge bottles with the cell pellets on ice.
6. Add 80 ml of sterile water to the bottle and vortex to resuspend the cell pellet.
7. Add 10 ml of 10x TE buffer; swirl to mix. Add 10 ml of lithium acetate (LiAc) stock solution; swirl to mix. Incubate 45 min at 30°C shaking at ~ 85 rpm.
8. Add 2.5 ml of 1 M DTT; swirl to mix. Incubate 15 min at 30°C shaking at ~ 85 rpm.
9. Bring the volume to 500 ml with sterile water. Pellet the cells by centrifugation at 4,000 x g for 5 min at 4°C; pour off and discard the supernatant.
10. Add ~ 50 ml of sterile, ice-cold water to the bottle and vortex to resuspend the cell pellet; bring the volume to 500 ml with sterile, ice-cold water. Pellet the cells by centrifugation at 4,000 x g for 5 min at 4°C; pour off and discard the supernatant.
11. Resuspend the cell pellet in 25–30 ml of sterile, ice-cold 1 M sorbitol and transfer to a chilled 30-ml Oakridge tube. Pellet the cells by centrifugation at 4,000 x g for 5 min at 4°C; pour off and discard the supernatant.
12. Resuspend the cell pellet in 0.5 ml of sterile, ice-cold 1 M sorbitol; the final cell volume should be 1.3–1.5 ml and the cell concentration should be $\sim 1 \times 10^{10}$ cells/ml. Keep the cells on ice and use as soon as possible for electroporation.

7.1.2 Electroporation

1. For each sample to be electroporated, prepare a 17 x 100-mm sterile tube with 1 ml of 1 M sorbitol and place on ice; also, place a 0.2-cm or 0.4-cm cuvette on ice.
2. Pipette the DNA samples (5–100 ng in a volume of 5 μ l) to be electroporated into sterile 1.5-ml microfuge tubes. Place tubes on ice.
3. If 0.2-cm cuvettes are used, add 40 μ l of the competent cells to each DNA sample; if 0.4-cm cuvettes are used, add 80 μ l of the competent cells to each DNA sample. Mix gently and incubate on ice for ~5 min.
4. From the Home screen on the Gene Pulser Xcell System open the Preset Protocols screen, then the Fungal Protocol screen (press 4, Enter, then 2, Enter). When using 0.2-cm cuvettes, press Enter to open the *S. cerevisiae*, 2-mm cuvette Protocol Detail screen. When using 0.4-cm cuvettes, press 2 then Enter to open the *S. cerevisiae*, 4-mm Protocol Detail screen. See Section 3.4 for operating instructions.
5. Transfer the DNA-cell samples to the appropriate electroporation cuvettes that have been chilled in ice and tap the suspension to the bottom. Place the cuvette in the ShockPod. Push the lid down to close. Pulse once.
6. Remove the cuvette from the chamber, immediately add 1 ml of ice-cold 1 M sorbitol to the cuvette, then gently transfer the diluted cells into a sterile 17 x 100-mm tube.
7. Check and record the pulse parameters. The time constant should be about 5 milliseconds. The voltage should be approximately 1.5 kV when pulsing the 0.2-cm cuvettes and approximately 2.5 kV when pulsing the 0.4-cm cuvettes.
8. Plate aliquots of the electroporated cells on selective agar plates containing 1 M sorbitol. Incubate plates for 48–72 hr at 30°C.

7.1.3 Solutions and Reagents

1. YPD: 10 g yeast extract, 20 g peptone, dissolve in 900 ml water. Autoclave. Add 100 ml of sterile 20% glucose.
2. 1 M sorbitol: 182.2 g sorbitol, dissolve in 800 ml water. Bring volume to 1.0 L with water. Autoclave.
3. 20% glucose: 20 g glucose, dissolve in 60 ml water. Adjust volume to 100 ml with water. Sterilize through a 0.22- μ m filter.

7.2 *Schizosaccharomyces pombe*

7.2.1 Preparation of Electrocompetent Cells

See Prentice 1991 for additional information.

Using this method we have obtained transformation efficiencies up to 3×10^5 transformants/ μ g electroporating *S. pombe* CHP408 with pART1 (Apolinario et al. 1993).

The Gene Pulser Xcell System conditions: C = 25 μ F; PC = 200 Ω ; V = 2.3 kV.

This procedure requires a Gene Pulser Xcell main unit and PC module.

1. Inoculate 200 ml of YCD in a 2.8-L Fernbach flask with an aliquot from an overnight culture of *S. pombe*. (An initial OD 600 of 0.1 is usually a good starting point.) The doubling time of *S. pombe* is approximately 2 hr at 30°C.

2. Incubate at 30°C overnight, shaking at 250 rpm, to late log phase (~2 x 10⁸ cells/ml; OD 600 [1:20 dilution] = 0.4–0.5).
3. Chill the cells in an ice-water bath for 15 min to stop growth.
4. Decant the cells into a sterile 250-ml centrifuge bottle and pellet the cells by centrifugation at 4,000 x g for 5 min at 4°C.
5. Carefully pour off and discard the supernatant; keep the cells on ice.
6. Add ~50 ml of sterile, ice-cold 1.2 M sorbitol and vortex to resuspend the cell pellet; bring the volume in each of the centrifuge bottles to ~250 ml. Pellet the cells by centrifugation at 4,000 x g for 5 min at 4°C; pour off and discard the supernatant.
7. Wash the cells again as in step 6 with a total of ~200 ml sterile, ice-cold 1.2 M sorbitol.
8. Resuspend the cell pellet with ~10 ml of sterile, ice-cold 1.2 M sorbitol and transfer to a chilled 30-ml Oakridge tube; rinse the centrifuge bottle with 15–20 ml of ice-cold 1.2 M sorbitol and transfer to the Oakridge tube. Pellet the cells by centrifugation at 4,000 x g for 5 min at 4°C; pour off and discard the supernatant.
9. Resuspend the cell pellet in 3 ml of sterile, ice-cold 1.2 M sorbitol. Keep the cells on ice and use as soon as possible for electroporation.

7.2.2 Electroporation

1. For each sample to be electroporated, prepare a 17 x 100-mm sterile tube with 1 ml of 1.2 M sorbitol and place on ice; also place a 0.2-cm cuvette on ice.
2. Pipette the DNA samples (up to 1 µg) to be electroporated into sterile 1.5-ml microfuge tubes. Place tubes on ice. Add 40 µl of the competent cells to each DNA sample and mix gently.
3. From the Home Screen on the Gene Pulser Xcell System open the Fungal Protocol Screen (press 4, Enter, 2, Enter). To select *S. pombe*, press 3 or the Down Arrow to highlight *S. pombe*, then press Enter to open the *S. pombe* Protocol Detail screen. See Section 3.4 for operating instructions.
4. Transfer the DNA-cell samples to the chilled 0.2-cm electroporation cuvettes and tap the suspension to the bottom. Place the cuvette in the ShockPod. Push the chamber lid down to close. Pulse once.
5. Remove the cuvette from the chamber and immediately add 1 ml of ice cold 1.2 M sorbitol to the cuvette; gently transfer the diluted cells to a sterile 17 x 100-mm tube.
6. Check and record the pulse parameters. The time constant should be close to 5 milliseconds. The voltage should be approximately 2.3 kV.
7. Incubate the tubes at room temperature for 40–60 min. Plate aliquots of the electroporated cells on selective agar plates without sorbitol (e.g., EMM). Incubate plates for 6–8 days at 30°C.

7.2.3 Solutions and Reagents

1. YCD medium: 10 g yeast extract, 2 g casamino acids, dissolve in 900 ml water. Autoclave. Add 100 ml of 20% glucose.

20% glucose: 100 g glucose, dissolve in 350 ml water; bring volume to 500 ml with water. Filter sterilize.

2. 1.2 M sorbitol: 218.6 g sorbitol, dissolve in ~700 ml water. Add water to 1.0 L. Autoclave.
3. EMM: 12.35 g EMM-dextrose, dissolve in 900 ml water. Pour 450 ml into each of two 1-L bottles and add 10.0 g agar to each bottle. Autoclave for 30 min. Cool to 55–60°C and add 50 ml 20% glucose to each bottle. Pour plates (sufficient for ~60 plates).

7.3 *Pichia pastoris*

7.3.1 Preparation of Electrocompetent Cells

See Cregg and Russell 1998 for additional information.

Using this method, we have obtained transformation efficiencies of $\sim 6 \times 10^4$ transformants/ μg electroporating *P. pastoris* X33 with Sacl-pPICZA (Thermo Fisher Scientific Inc.).

The Gene Pulser Xcell System conditions: C = 25 μF ; PC = 200 Ω ; V = 2.0 kV.

This procedure requires a Gene Pulser Xcell main unit and PC module.

1. Inoculate 500 ml of YPD in a 2.8-L Fernbach flask with an aliquot from a fresh overnight culture of *P. pastoris*. The doubling time of *P. pastoris* is approximately 2 hr at 30°C.
2. Incubate at 30°C overnight, shaking at 300 rpm, to a density of $\sim 7 \times 10^7$ cells/ml (OD 600 [1:10 dilution] = 0.24–0.30).
3. Decant the cells into a sterile 500-ml centrifuge bottle and pellet the cells by centrifugation at 3,000 x g for 5 min at 4°C.
4. Carefully pour off and discard the supernatant.
5. Add 100 ml of sterile, YPD/HEPES to each of the bottles and vortex to resuspend the cell pellets; add 2.5 ml of 1 M DTT; mix gently. Incubate the cells for 15 min at 30°C without shaking.
6. Bring the volume to ~500 ml with sterile, ice-cold 1 M sorbitol. Pellet the cells by centrifugation at 3,000 x g for 5 min at 4°C; pour off and discard the supernatant.
7. Add ~50 ml of sterile, ice-cold 1 M sorbitol and vortex to resuspend the cell pellets; bring the volume to 500 ml with sterile, ice-cold 1 M sorbitol. Pellet the cells by centrifugation at 3,000 x g for 5 min at 4°C; pour off and discard the supernatant.
8. Resuspend the cell pellet in ~25 ml of sterile, ice-cold 1 M sorbitol and transfer to a chilled 30-ml Oakridge tube. Pellet the cells by centrifugation at 3,000 x g for 5 min at 4°C; pour off and discard the supernatant.
9. Resuspend the cell pellet in 0.5 ml of sterile, ice-cold 1 M sorbitol; the final cell volume should be ~1.3 ml and the cell concentration should be $>1 \times 10^{10}$ cells/ml. Keep the cells on ice and use as soon as possible for electroporation.

7.3.2 Electroporation

1. For each sample to be electroporated, prepare a 17 x 100-mm sterile tube with 1.0 ml of 1 M sorbitol and place on ice; also place a 0.2-cm cuvette on ice.
2. Pipette the DNA samples (up to 0.1 μg) to be electroporated into sterile 1.5-ml microfuge tubes. Place tubes on ice.

3. Add 40 μ l of the competent cells to each DNA sample and mix gently.
4. From the Home Screen on the Gene Pulser Xcell System open the Fungal Protocol Screen (press 4, Enter, 2, Enter). To select *P. pastoris*, press 5 or the Down Arrow to highlight *P. pastoris*, then press Enter to open the *P. pastoris* Protocol Detail screen. See Section 3.4 for operating instructions.
5. Transfer the DNA-cell samples to the 0.2-cm electroporation cuvettes that have been chilled in ice and tap the suspension to the bottom. Place the cuvette in the ShockPod. Push the chamber lid down to close. Pulse once.
6. Remove the cuvette from the chamber and immediately add 1.0 ml of ice-cold 1 M sorbitol to the cuvette; gently transfer the diluted cells to a sterile 17 x 100-mm tube.
7. Check and record the pulse parameters. The time constant should be close to 5 milliseconds. The voltage should be approximately 2.0 kV.
8. When selecting for complementation of an auxotrophic mutant, the cells may be plated immediately onto minimal agar plates lacking the appropriate nutrient. When selecting for antibiotic resistance, incubate the cells at 30°C for 1 hr without shaking; add 1 ml of 1 M sorbitol and continue incubating for 1 hr; plate aliquots of the electroporated cells on YPD agar plates with the appropriate antibiotic. Incubate the plates for 72–96 hr at 30°C.

7.3.3 Solutions and Reagents

1. YPD: 10 g yeast extract, 20 g peptone, dissolve in 900 ml water. Autoclave. Add 100 ml sterile 20% glucose.
2. YPD/HEPES: 100 ml YPD medium, 20 ml 1 M HEPES, pH 8.0.
3. 1 M sorbitol: 182.2 g sorbitol, dissolve in 800 ml water. Bring volume to 1.0 L with water. Autoclave.
4. 20% glucose: 20 g glucose, dissolve in 60 ml water. Adjust volume to 100 ml with water. Sterilize through a 0.22- μ m filter.
5. 1 M HEPES, pH 8.0: 23.8 g HEPES (MW = 238.3), dissolve in ~65 ml water. Adjust pH to 8.0 with 5 N NaOH. Bring volume to 100 ml with water. Sterilize through a 0.22- μ m filter.
6. 1 M DTT: 3.85 g DTT, dissolve in ~22 ml water. Bring volume to 25 ml with water. Sterilize through a 0.22- μ m filter.

7.4 *Candida albicans*

7.4.1 Preparation of Electrocompetent Cells

See deBacker et al. 1999 for additional information.

Using this method, we have obtained transformation efficiencies of >400 transformants/ μ g electroporating *C. albicans* CAI4 with NheI-pUX (Thompson et al. 1998).

The Gene Pulser Xcell System conditions: C = 25 μ F; PC = 200 Ω ; V = 1.5 kV.

This procedure requires a Gene Pulser Xcell main unit and PC module.

1. Inoculate a colony of *C. albicans* into 5–6 ml of YPD/uridine medium in a 17 x 100-mm tube; incubate overnight at 30°C shaking at 250–300 rpm.

- Inoculate an aliquot of the overnight culture into 500 ml of YPD/uridine medium in a 2.8-L Fernbach flask; incubate overnight at 30°C shaking at 250–300 rpm to a density of 5–10 × 10⁷ cells/ml (OD 600 [1:10 dilution] = 0.3–0.45).
- Chill the culture on ice for 10 min.
- Transfer the cells into a sterile 500-ml centrifuge bottle.
- Pellet the cells by centrifugation at 15–20°C for 5 min at 3,000 × g.
- Discard the supernatant. Resuspend the cell pellet in 125 ml of sterile 5 mM LiAc/10 mM DTT; incubate at 20°C for 1 hr.
- Pellet the cells at 4°C for 5 min at 3,000 × g.
- Discard the supernatant. Resuspend the pellet in 125 ml of sterile, ice-cold water. Pellet the cells as above.
- Discard the supernatant. Resuspend the cell pellet in 125 ml of ice-cold water. Pellet the cells as above.
- Discard the supernatant. Resuspend the cell pellet in 35 ml of ice-cold 1 M sorbitol. Transfer the cells to a chilled Oakridge tube. Pellet the cells at 4°C for 5 min at 3,000 × g.
- Carefully remove the supernatant. Resuspend the pellet in 0.5 ml of ice-cold 1 M sorbitol.
- Keep the cells on ice and use as soon as possible for electroporation.

7.4.2 Electroporation

- For each sample to be electroporated, prepare a 17 × 100-mm sterile tube with 1.0 ml of 1 M sorbitol and place on ice; also place a 0.2-cm cuvette on ice.
- Pipette the linearized DNA samples (0.1–1 µg) to be electroporated into sterile 1.5-ml microfuge tubes. Place tubes on ice.
- Add 40 µl of the electrocompetent cells to each DNA sample and mix gently. Incubate the cells on ice for 5 min.
- From the Home Screen on the Gene Pulser Xcell System open the Fungal Protocol Screen (press 4, Enter, 2, Enter). To select *C. albicans*, press 4 or the Down Arrow to highlight *C. albicans*, then press Enter to open the *C. albicans* Protocol Detail screen. See Section 3.4 for operating instructions.
- Transfer the DNA-cell samples to the 0.2-cm electroporation cuvettes that have been chilled in ice and tap the suspension to the bottom. Place the cuvette in the ShockPod. Push the chamber lid down to close. Pulse once.
- Remove the cuvette from the chamber and immediately add 1.0 ml of ice cold 1 M sorbitol to the cuvette; gently transfer the diluted cells to a sterile 17 × 100-mm tube.
- Check and record the pulse parameters. The time constant should be close to 5 milliseconds. The voltage should be approximately 1.5 kV.
- Immediately plate an aliquot of the cells onto minimal agar plates containing 1 M sorbitol but lacking the appropriate nutrient. Incubate the plates for 4–6 days at 30°C.

7.4.3 Solutions and Reagents

1. YPD / uridine: 10 g yeast extract, 20 g peptone, dissolve in 900 ml water; add 15 g agar. Autoclave. Add 100 ml sterile 20% glucose, 1 ml 25 mg/ml uridine.
2. YPD / uridine agar: 10 g yeast extract, 20 g peptone, dissolve in 900 ml water. Autoclave. Add 100 ml sterile 20% glucose, 1 ml 25 mg/ml uridine.
3. 1 M sorbitol: 182.2 g sorbitol, dissolve in 800 ml water. Bring volume to 1.0 L with water. Autoclave.
4. 20% glucose: 20 g glucose, dissolve in 60 ml water. Adjust volume to 100 ml with water. Sterilize through a 0.22 μ m filter.
5. 5 mM LiAc / 10 mM DTT in TE: 1 ml 1 M LiAc (10.2 g/100 ml), 20 ml 0.1 M DTT (1.54 g/100 ml), 2 ml 1 M Tris, pH 7.5, 0.4 ml 0.5 M EDTA, 176.6 ml water. Filter sterilize. Store at -20°C .
6. 1 M sorbitol: 182.2 g sorbitol, dissolve in 800 ml water. Bring volume to 1.0 L with water. Autoclave.

7.5 *Dictyostelium discoideum*

7.5.1 Preparation of Electrocompetent Cells

See Howard et al. 1988 and Knecht & Pang 1995 for additional information.

Gene Pulser Xcell conditions: square-wave, $V = 1.0$ kV, 1.0 ms pulse length, 2 pulses, 5-sec pulse interval; $V = 1.0$ kV.

1. Inoculate *D. discoideum* cells at a concentration of $5\text{--}7 \times 10^5$ cells/ml into 40 ml of HL5 medium in a 500-ml flask. The cells may either be scraped from a plate or transferred from liquid medium. The doubling time of *D. discoideum* is approximately 12 hr at 21°C .
2. Incubate the culture at 21°C for about 24 hr, shaking at 125 rpm. About 16–20 hr prior to preparing the competent cells, dilute the cells to 7×10^5 cells/ml with HL5 medium. Incubate at 21°C overnight, shaking at 125 rpm.
3. Transfer 100 ml of the cells into two sterile, disposable, 50-ml centrifuge tubes and incubate on ice for 15 min to stop growth.
4. Pellet the cells by centrifugation at $400 \times g$ for 5–7 min at room temperature.
5. Carefully pour off and discard the supernatant; place the centrifuge bottles with the cell pellets on ice.
6. Pool the cell pellets and resuspend in 50 ml of sterile, ice-cold E buffer. Pellet the cells by centrifugation at $400 \times g$ for 5–7 min at room temperature.
7. Carefully pour off and discard the supernatant; place the centrifuge bottles with the cell pellets on ice and resuspend the cells at a concentration of 1×10^7 cells/ml. Keep the cells on ice and use as soon as possible for electroporation.

7.5.2 Electroporation

1. Pipette the DNA samples (up to 50 μ g) to be electroporated into sterile 1.5-ml microfuge tubes. Place tubes on ice.
2. Add 800 μ l of the competent cells to each DNA sample and pipette up and down to mix; incubate on ice ~1 min.

3. From the Home Screen on the Gene Pulser Xcell System open the Fungal Protocol Screen (press 4, Enter, 2, Enter). To select *D. discoideum*, press 6 or the Down Arrow to highlight *D. discoideum*, then press Enter to open the *D. discoideum* Protocol Detail screen. See Section 3.4 for operating instructions.
4. Transfer the DNA-cell samples to 0.4-cm electroporation cuvettes that have been chilled in ice and tap the suspension to the bottom of the tube. Place the cuvette in the ShockPod. Push the chamber lid down to close. Pulse once (the program delivers two pulses, each with a ~1 ms time constant approximately 5 sec apart).
5. Remove the cuvette from the chamber and immediately dilute the cells to 10 ml with the appropriate medium.
6. Check and record the pulse parameters. The time constant should be 1 millisecond. The voltage should be approximately 1.0 kV.
7. When selecting for complementation of an auxotrophic mutant, the cells may be plated immediately into selective medium lacking the appropriate nutrient. When selecting for antibiotic resistance, incubate the cells overnight at 21°C prior to adding the selective agent.

7.5.3 Solutions and Reagents

1. HL5 medium: 17.8 g bacteriological peptone (Thermo Fisher Scientific), 7.2 g yeast extract, 0.54 g Na₂HPO₄, 0.4 g KH₂PO₄, 130 µl B12/folic acid mix; bring to 1 L with water and adjust to pH 6.3–6.5. Autoclave for 25 min on two successive days. Prior to use, add 20 ml of 50% glucose and 10 ml of 100x antibiotic-antimycotic (Thermo Fisher Scientific).
2. B12/folic acid mix: 5 mg B12, 200 mg folic acid; add 95 ml water, then adjust pH to 6.5–6.8 with 5 N NaOH; bring to 100 ml with water. Filter sterilize and store at –20°C protected from light.
3. E buffer: 10 ml 100 mM NaH₂PO₄, adjusted to pH 6.1 with KOH, 10 ml 0.5 M sucrose, 80 ml water; autoclave.

Section 8 Electroporation of Mammalian Cells

This procedure requires a Gene Pulser Xcell main unit and CE module.

8.1 Preparation of Electrocompetent Cells

8.1.1 Attached Cells

1. One to two days prior to electroporation, transfer the cells into 75-cm² flasks with fresh growth medium so that they will be 50–70% confluent on the day of the experiment. For most cell lines, the cell density will be 2–10 × 10⁶ cells/flask; about 1–10 × 10⁵ cells are needed per electroporation.
2. Aspirate the medium and rinse the flasks using ~12 ml of PBS.
3. Aspirate the PBS and add ~0.4 ml of trypsin-EDTA; incubate the cells 2–5 min at room temperature. Tap the flask to detach the cells from the surface.
4. Neutralize the trypsin by adding 10 ml of growth medium with serum.

- Transfer the cells to a 50-ml sterile centrifuge tube; pellet the cells by centrifugation at 400 x g for 5–7 min at room temperature.
- Aspirate the medium, then resuspend the cell pellet in electroporation buffer (Opti-MEM, growth medium without serum, PBS, HEPES-buffered saline, phosphate-buffered sucrose, or HEPES-buffered sucrose) to a density of $1\text{--}5 \times 10^6$ cells/ml. Gently pipette the cells to obtain a single-cell suspension.

8.1.2 Suspension Cells

- One to two days prior to electroporation, dilute the cells into fresh growth medium in a 75-cm² flask so that they will be in mid-log phase (generally about $0.5\text{--}4 \times 10^6$ cells/ml) on the day of the experiment. About $1\text{--}10 \times 10^5$ cells are needed per electroporation.
- Transfer the cells to a 50-ml sterile centrifuge tube; pellet the cells by centrifugation at 400 x g for 5–7 min at room temperature.
- Aspirate the medium, then resuspend the cell pellets in electroporation buffer (Opti-MEM, growth medium without serum, PBS, HEPES-buffered saline, phosphate-buffered sucrose, or HEPES-buffered sucrose) to a density of $1\text{--}5 \times 10^6$ cells/ml. Gently pipette the cells to obtain a single-cell suspension. For all Preset Protocols programmed in the Gene Pulser Xcell System, we recommend that cells be resuspended in Opti-MEM or in growth medium without serum.

8.2 Electroporation

- Set the desired pulse conditions on the Gene Pulser Xcell System. If a Preset Protocol is used (see Table 3.4), open the Mammalian Preset Protocols screen as follows: from the Home screen, press 4, Enter, 3, Enter; use the alpha-numeric keypad or the Up and Down Arrow keys to select the cell line, then press Enter to open the appropriate Protocol Detail screen.
- Add plasmid DNA(s) to the electroporation cuvettes. The amount of DNA required per sample is dependent on the cell type. Start with a concentration of 10–50 µg/ml.
- Add cells to the cuvette and tap the side of the cuvette to mix. See Table 8.1 for suggestions on cell concentrations and volumes to use.
- Place the cuvette in the ShockPod. Push down the lid to close. Pulse once.
- Immediately after the pulse, transfer the cells to a plate using ~0.5 ml of medium and a plugged Pasteur pipette.
- Rock the plates gently to assure even distribution of the cells over the surface of the plate. Incubate the plates at 37°C in a humidified atmosphere.
- Assay transient gene expression 24–48 hr following electroporation.

Table 8.1. Suggested starting cell concentrations and volumes for electroporating mammalian cells.

Cuvette, cm	Cell Concentration, cells/ml	Cell Volume, µl	Growth Conditions Following Electroporation
0.2	1×10^6	100	48-well plate with 0.5 ml growth medium
0.2	5×10^6	200	6-well plate with 2 ml growth medium
0.4	2.5×10^6	400	6-well plate with 2 ml growth medium

8.3 Reagents and Solutions for Electroporation

1. Growth medium with 10% fetal bovine serum (FBS).
2. Opti-MEM (Thermo Fisher Scientific).
3. Trypsin-EDTA: 0.05% trypsin, 0.53 mM EDTA in PBS (Bio-Rad).
4. PBS: 137 mM NaCl, 2.7 mM KCl, 9.5 mM sodium phosphate, pH 7.3; autoclave.
5. HEPES-buffered saline: 10 mM HEPES, pH 7.3, 140 mM NaCl; autoclave.
6. Phosphate-buffered sucrose: 272 mM sucrose, 10 mM sodium phosphate, pH 7.3; filter sterilize.
7. HEPES-buffered sucrose: 272 mM sucrose, 10 mM HEPES, pH 7.3; filter sterilize.

Section 9 References

- Anderson MLM et al. (1991). Electroporation of lymphoid cells: Factors affecting the efficiency of transfection. *J Biochem Biophys Meth* 22, 207–222.
- Andreason GL and Evans GA (1989). Optimization of electroporation for transfection of mammalian cell lines. *Anal Biochem* 180, 269–275.
- Apolinario E et al. (1993). Cloning and manipulation of the *Schizosaccharomyces pombe* his7+ gene as a new selectable marker for molecular genetic studies. *Curr Genet* 24, 491–495.
- Ausubel FM et al. (1987). *Current Protocols in Molecular Biology* (New York: John Wiley & Sons).
- Barsoum J (1995). Stable integration of vectors at high copy number for high-level expression in animal cells. In *Methods in Molecular Biology*, J. A. Nickoloff, ed. (Totowa, NJ: Humana Press) 48, p. 225.
- Becker DM and Guarente L (1991). High-efficiency transformation of yeast by electroporation. *Methods Enzymol* 194, 182–187.
- Böttger EC (1988). High-efficiency generation of plasmid cDNA libraries using electro-transformation. *Biotechniques* 6, 878–880.
- Bringel F and Hubert J-C (1990). Optimized transformation by electroporation of *Lactobacillus plantarum* strains with plasmid vectors. *Appl Microbiol Biotechnol* 33, 664–670.
- Calvin NM and Hanawalt PC (1988). High-efficiency transformation of bacterial cells by electroporation. *J Bacteriol* 170, 2,796–2,801.
- Chaffin DO and Rubens CE (1998). Blue/white screening of recombinant plasmids in Gram-positive bacteria by interruption of alkaline phosphatase gene (phoZ) expression. *Gene* 219, 91–99.
- Change DC et al. (1992). *Guide to Electroporation and Electrofusion* (San Diego: Academic Press, Inc.).
- Chu G et al. (1987). Electroporation for the efficient transfection of mammalian cells with DNA. *Nucleic Acids Res* 15, 1,311–1,326.
- Cregg JM and Russell KA (1998). Transformation. In *Methods in Molecular Biology*, D. R. Higgins and J. M. Cregg, eds. (Totowa, NJ: Humana Press), pp. 27–39.
- DeBacker MD et al. (1999). Transformation of *Candida albicans* by electroporation. *Yeast* 15, 1,609–1,618.
- Dekeyser RA et al. (1990). Transient gene expression in intact and organized rice tissues. *The Plant Cell* 2, 591–602.
- Dennis JJ and Sokol PA (1995). Electrotransformation of *Pseudomonas*. In *Methods in Molecular Biology*, J. A. Nickoloff, ed. (Totowa, NJ: Humana Press), p. 125.
- Dower WJ (1990). Electroporation of bacteria: A general approach to genetic transformation. In *Genetic Engineering—Principles and Methods*, J. K. Setlow, ed. (New York: Plenum Publishing Corp.), pp. 275–295.
- Dower WJ et al. (1988). High efficiency transformation of *E. coli* by high voltage electroporation. *Nucleic Acids Res* 16, 6,127–6,145.
- Dower WJ (1992). Protocols for the transformation of bacteria by electroporation. In *Guide to Electroporation and Electrofusion*, D. C. Change et al., eds. (San Diego: Academic Press Inc.), p. 485.
- Fromm M et al. (1987). Electroporation of DNA and RNA into plant protoplasts. *Methods Enzymol* 153, 351–366.
- Gaertig J and Gorovsky MA (1995). Gene transfer by electroporation in *Tetrahymena*. *Methods Mol Biol* 47, 331–348.
- Grey M and Brendel MF (1995). Ten-minute electrotransformation of *Saccharomyces cerevisiae*. In *Methods in Molecular Biology*, J. A. Nicoloff, ed. (Totowa, NJ: Humana Press) 47, pp. 269–272.
- Haque H and Russell AD (1974). Effect of ethylene-diamine-tetraacetic acid and related chelating agents on whole cells of gram-negative bacteria. *Antimicrob Agents Chemother* 5, 447–452.
- Heery DM and Dunican LK (1989). Improved efficiency M13 cloning using electroporation. *Nucleic Acids Res* 17, 8,006.

- Heiser WC (2000). Optimizing electroporation conditions for the transformation of mammalian cells. *Methods Mol Biol* 130, 117–134.
- Hui SW (1995). Effects of pulse length and strength on electroporation efficiency. *Methods Mol Biol* 55, 29–40.
- Howard PK et al. (1988). Establishment of a transient expression system for *Dictyostelium discoideum*. *Nucleic Acids Res* 16, 2,613–2,623.
- Jacobs M et al. (1990). High-efficiency electro-transformation of *Escherichia coli* with DNA from ligation mixtures. *Nucleic Acids Res* 18, 1,653.
- Joersbo M and Brunstedt J (1991). Electroporation: Mechanism and transient expression, stable transformation and biological effects in plant protoplasts. *Physiol Plant* 81, 256–264.
- Knecht D and Pang KM (1995). Electroporation of *Dictyostelium discoideum*. In *Methods in Molecular Biology*, J. A. Nickoloff, ed. (Totowa, NJ: Humana Press), pp. 321–330.
- Knutson JC and Yee D (1987). Electroporation: parameters affecting transfer of DNA into mammalian cells. *Anal Biochem* 164, 44–52.
- Lee JC (1995). Electrotransformation of Staphylococci. In *Methods in Molecular Biology*, J. A. Nickoloff, ed. (Totowa, NJ: Humana Press), pp. 209–216.
- Lin J-J (1995). Electrotransformation of *Agrobacterium*. In *Methods in Molecular Biology*, J. A. Nickoloff, ed. (Totowa, NJ: Humana Press), pp. 171–178.
- Miller EM and Nickoloff JA (1995). *Escherichia coli* electrotransformation. In *Methods in Molecular Biology*, J. A. Nickoloff, ed. (Totowa, NJ: Humana Press), pp. 105–113.
- Neumann et al. (2000). Principles of membrane electroporation and transport of macromolecules. *Methods Mol Med*, 37, 1–35.
- Prentice HL (1991). High efficiency transformation of *Schizosaccharomyces pombe* by electroporation. *Nucleic Acids Res* 20, 621.
- Potter H et al. (1984). Enhancer-dependent expression of human k immunoglobulin genes introduced into mouse pre-B lymphocytes by electroporation. *Proc Natl Acad Sci* 81, 7,161–7,165.
- Ray FA (1995). Electroporation of plasmid DNA into normal human fibroblasts. In *Methods in Molecular Biology*, J. A. Nickoloff, ed. (Totowa, NJ: Humana Press) 48, pp. 133–140.
- Shigekawa K and Dower WJ (1988). Electroporation of eukaryotes and prokaryotes: A general approach to the introduction of macromolecules into cells. *Biotechniques* 6, 742–751.
- Shillito RD et al. (1985). High efficiency direct gene transfer to plants. *Nat Biotechnol* 3, 1,099–1,103.
- Showe et al. (1992). Quantitation of transient gene expression after electroporation. *Nucleic Acids Res* 20, 3,153–3,157.
- Silo-Suh LA et al. (1994). Biological activities of two fungistatic antibiotics produced by *Bacillus cereus* UW85. *Appl Environ Microbiol* 60, 2,023–2,030.
- Simon D and Ferretti JJ (1991). Electrotransformation of *Streptococcus pyogenes* with plasmid and linear DNA. *FEMS Microbiol Lett* 82, 219–224.
- Smith AW and Iglewski BH (1989). Transformation of *Pseudomonas aeruginosa* by electroporation. *Nucleic Acids Res* 17, 10,509.
- Thompson JR et al. (1998). An improved protocol for the preparation of yeast cells for transformation by electroporation. *Yeast* 14, 565–571.
- Trevors et al. (1992). Electrotransformation of bacteria by plasmid DNA. In *Guide to Electroporation and Electrofusion*. D. C. Change et al., eds. (San Diego: Academic Press Inc.), p. 265.
- Willson TA and Gough NM (1988). High voltage *E. coli* electro-transformation with DNA following ligation. *Nucleic Acids Res* 16, 11,820.
- Zabarovsky ER and Winberg G (1990). High efficiency electroporation of ligated DNA into bacteria. *Nucleic Acids Res* 18, 5,912.

Section 10

Specifications and Product Information

10.1 System Specifications

1652660 Gene Pulser Xcell Total System

Includes main unit, CE module, PC module

Outputs	Waveform: exponential decay or square-wave Voltage: 10–3,000 V
Capacitance	10–500 V, 25–3,275 mF in 25-mF increments 500–3,000 V, 10, 25, 50 mF
Resistance (Parallel)	50–1,000 Ω in 50- Ω increments plus infinity
Sample Resistance	20 Ω minimum at 10–2,500 V 600 Ω minimum at 2,500–3,000 V
Square-Wave Timing	10–500 V: 0.05–100 ms pulse length, 1–10 pulses, 0.1–10 sec pulse interval 500–3,000 V: 0.05–5 ms pulse length, 1–2 pulses, 5–30 sec pulse interval

1652661 Gene Pulser Xcell Eukaryotic System

Includes main unit, CE module

Outputs same as Total System without the parallel resistance.

1652662 Gene Pulser Xcell Microbial System

Includes main unit, PC module

Outputs	Waveform: exponential decay or square-wave Voltage: 200–3,000 V
Capacitance	10, 25, 50 μ F
Resistance (Parallel)	50–1,000 Ω in 50- Ω increments plus infinity
Sample Resistance	20 Ω minimum at 200–2,500 V 600 Ω minimum at 2,500–3,000 V
Square-Wave Timing	0.05–5 ms pulse length, 1–2 pulses, 5–30 pulse interval

1652666 Gene Pulser Xcell Main Unit

Outputs	Waveform: exponential decay or square-wave Voltage: 200–3,000 V
Discharge Capacitance	10, 25, 50 μ F
Sample Resistance	20 Ω minimum at 200–2,500 V 600 Ω minimum at 2,500–3,000 V
Square-Wave Timing	0.05–5 ms pulse length, 1–2 pulses, 5–30 sec pulse interval

General

Input Voltage	100–120 VAC or 220–240 VAC, 50/60 Hz
Power	Max 240 W (during short charging periods)
Operating Environment	Temperature 0–35°C, indoor use, humidity 0–95% (in the absence of condensation)
Regulatory	Safety EN 61010-1, EMC EN61326 Class A
Dimensions	Main Unit: 31 x 30 x 14 cm, weight 6.62 kg CE module: 31 x 28 x 9 cm, weight 3.08 kg PC module: 31 x 28 x 5 cm, weight 1.90 kg

10.2 Ordering Information

Catalog #	Description
1652660	Gene Pulser Xcell Total System for eukaryotic and microbial cells, 100/240 V, 50/60 Hz, exponential-decay and square-wave delivery, includes main unit, CE module, PC module, ShockPod, 15 sterile cuvettes (5 each of 0.1, 0.2, and 0.4 cm gap), instruction manual
1652661	Gene Pulser Xcell Eukaryotic System , 100/240 V, 50/60 Hz, includes main unit, CE module for exponential-decay or square-wave pulses, shocking chamber, 5 x 0.4 cm gap sterile electroporation cuvettes, cuvette rack
1652662	Gene Pulser Xcell Microbial System , 100/240 V, 50/60 Hz, includes main unit, PC module for exponential-decay pulse delivery, shocking chamber, 5 each of 0.1 and 0.2 cm gap sterile electroporation cuvettes, cuvette rack
1652666	Gene Pulser Xcell Main Unit , 100/240 V, 50/60 Hz
1652667	Gene Pulser Xcell CE Module , capacitance extender for use with the Gene Pulser Xcell electroporation system, functional range of 25–3,275 μ F, includes integral leads
1652668	Gene Pulser Xcell CE Module , pulse controller module for use with the Gene Pulser Xcell electroporation system, range of 50–1,000 Ω , includes integral leads
1652669	Gene Pulser Xcell ShockPod Cuvette Chamber , electroporation chamber of the Gene Pulser Xcell and Gene Pulser II electroporation systems, includes integral leads
1652095	Gene Pulser Cuvette Rack
1652088	Gene Pulser Cuvettes , 0.4-cm gap, 50, sterile
1652086	Gene Pulser Cuvettes , 0.2-cm gap, 50, sterile
1652089	Gene Pulser Cuvettes , 0.1-cm gap, 50, sterile
1652091	Gene Pulser Cuvettes , 0.4-cm gap, 500, sterile
1652092	Gene Pulser Cuvettes , 0.2-cm gap, 500, sterile
1652093	Gene Pulser Cuvettes , 0.1-cm gap, 500, sterile
1652081	Gene Pulser Cuvettes , 0.4-cm gap, 5, sterile
1652082	Gene Pulser Cuvettes , 0.2-cm gap, 5, sterile
1652083	Gene Pulser Cuvettes , 0.1-cm gap, 5, sterile

Visit bio-rad.com/xcell for more information.

BIO-RAD and GENE-PULSER are trademarks of Bio-Rad Laboratories, Inc. in certain jurisdictions. All trademarks used herein are the property of their respective owner.



**Bio-Rad
Laboratories, Inc.**

Life Science
Group

Website bio-rad.com **USA** 1 800 424 6723 **Australia** 61 2 9914 2800 **Austria** 00 800 00 24 67 23 **Belgium** 00 800 00 24 67 23
Brazil 4003 0399 **Canada** 1 905 364 3435 **China** 86 21 6169 8500 **Czech Republic** 00 800 00 24 67 23 **Denmark** 00 800 00 24 67 23
Finland 00 800 00 24 67 23 **France** 00 800 00 24 67 23 **Germany** 00 800 00 24 67 23 **Hong Kong** 852 2789 3300
Hungary 00 800 00 24 67 23 **India** 91 124 4029300 **Israel** 0 3 9636050 **Italy** 00 800 00 24 67 23 **Japan** 81 3 6361 7000
Korea 82 2 3473 4460 **Luxembourg** 00 800 00 24 67 23 **Mexico** 52 555 488 7670 **The Netherlands** 00 800 00 24 67 23
New Zealand 64 9 415 2280 **Norway** 00 800 00 24 67 23 **Poland** 00 800 00 24 67 23 **Portugal** 00 800 00 24 67 23
Russian Federation 00 800 00 24 67 23 **Singapore** 65 6415 3188 **South Africa** 00 800 00 24 67 23 **Spain** 00 800 00 24 67 23
Sweden 00 800 00 24 67 23 **Switzerland** 00 800 00 24 67 23 **Taiwan** 886 2 2578 7189 **Thailand** 66 2 651 8311
United Arab Emirates 36 1 459 6150 **United Kingdom** 00 800 00 24 67 23

